

INSTALLATION INSTRUCTIONS

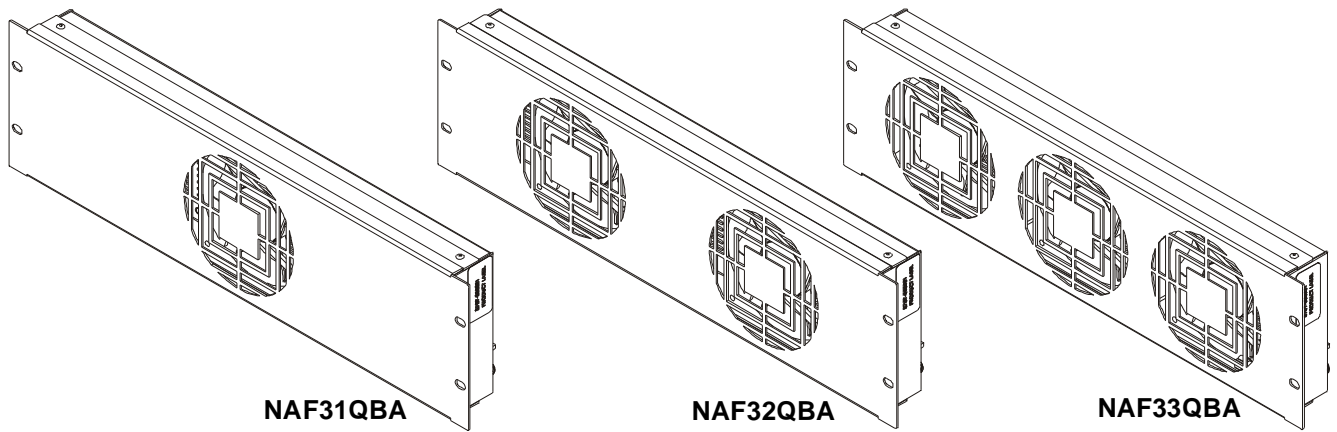

3U Fan Panel Accessories

DISCLAIMER

Milestone AV Technologies and its affiliated corporations and subsidiaries (collectively "Milestone"), intend to make this manual accurate and complete. However, Milestone makes no claim that the information contained herein covers all details, conditions or variations, nor does it provide for every possible contingency in connection with the installation or use of this product. The information contained in this document is subject to change without notice or obligation of any kind. Milestone makes no representation of warranty, expressed or implied, regarding the information contained herein. Milestone assumes no responsibility for accuracy, completeness or sufficiency of the information contained in this document.

Chief® is a registered trademark of Milestone AV Technologies. All rights reserved.

! IMPORTANT WARNINGS AND CAUTIONS!

! WARNING: A WARNING alerts you to the possibility of serious injury or death if you do not follow the instructions.

! CAUTION: A CAUTION alerts you to the possibility of damage or destruction of equipment if you do not follow the corresponding instructions.

! WARNING: Failure to read, thoroughly understand, and follow all instructions can result in serious personal injury, damage to equipment, or voiding of factory warranty! It is the installer's responsibility to make sure all components are properly assembled and installed using the instructions provided.

DIMENSIONS

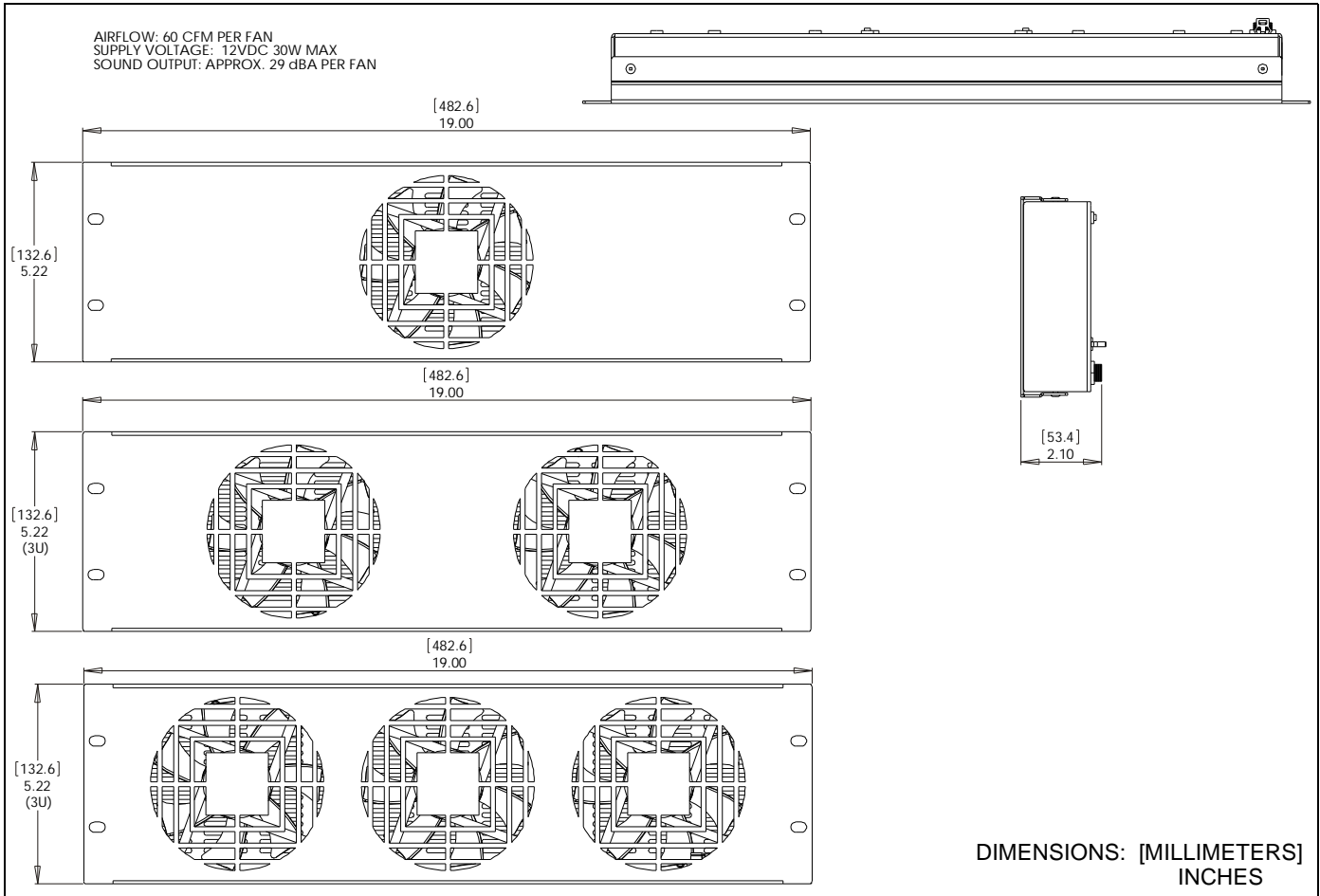

TOOLS / HARDWARE / PARTS

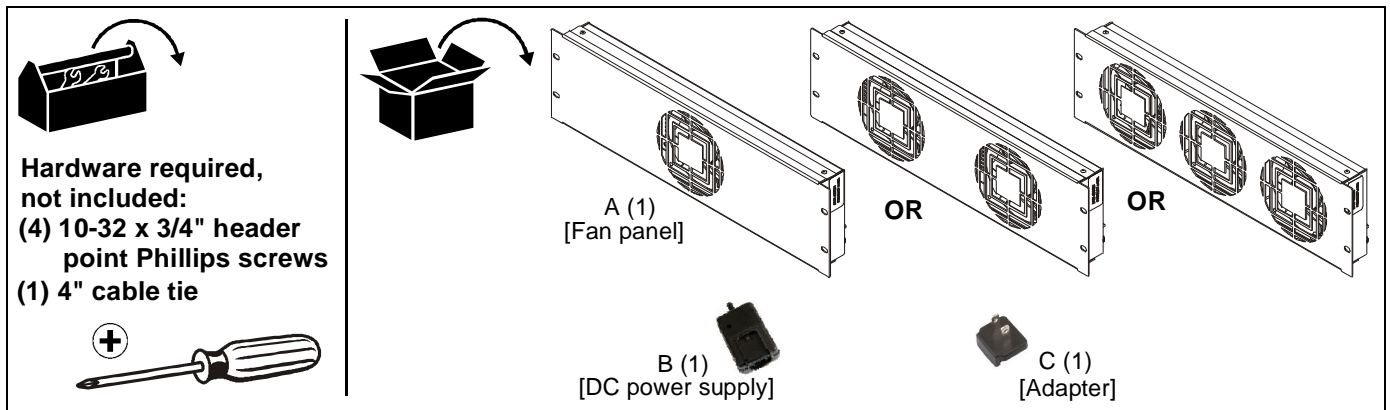

ASSEMBLY AND INSTALLATION

NOTE: The NAF31-32-33QBA fan panels are designed for use with 19" wide equipment racks. See the specific installation instructions provided with the rack for additional installation information.

1. Attach the fan panel (A) within the rack, using four 10-32 x 3/4" header point Phillips screws (not included). (See Figure 1)

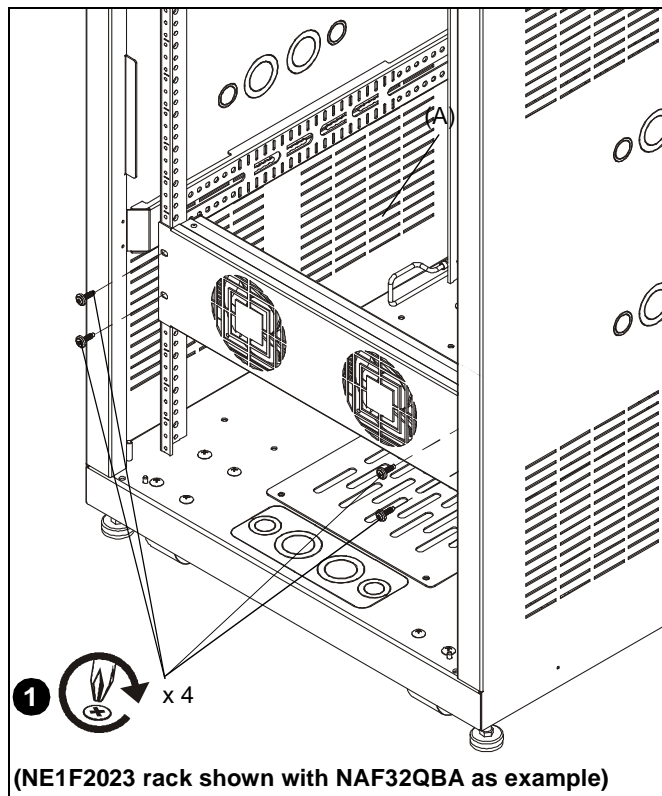

Figure 1

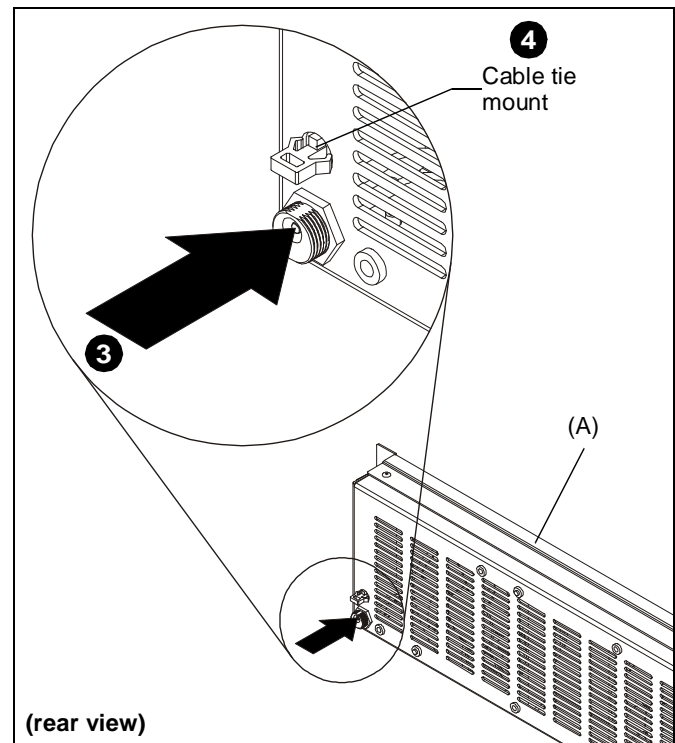

Figure 2

2. Plug the adapter (C) into the DC power supply (B).
3. Plug power supply into back of fan panel (A). (See Figure 2)
4. Secure power supply plug using a cable tie (not included) through the cable tie mount. (See Figure 2)



Our Mounts. **Your Vision.**

Chief, a products division of
Milestone AV Technologies

8800-002909 Rev00
©2016 Milestone AV Technologies
www.milestone.com
12/16

USA/International	A 6436 City West Parkway, Eden Prairie, MN 55344 P 800.582.6480 / 952.225.6000 F 877.894.6918 / 952.894.6918
Europe	A Franklinstraat 14, 6003 DK Weert, Netherlands P +31 (0) 495 580 852 F +31 (0) 495 580 845
Asia Pacific	A Office No. 918 on 9/F, Shatin Galleria 18-24 Shan Mei Street Fotan, Shatin, Hong Kong P 852 2145 4099 F 852 2145 4477

