



EASE
EQUIPMENT ANCHORAGE & SEISMIC ENGINEERING
 2801 Connery Way Suite B
 Missoula, MT 59808
 Phn: (406) 541-3273 Fax: (406) 541-3274

Office of Statewide Health Planning and Development
ANCHORAGE PRE-APPROVAL

OPA-1364-07

Equipment Manufacturer: Milestone AV Technologies

Equipment Type: Chief - CMA - 110 Projector Mount

GENERAL NOTES

1. FORCES PER ASCE 7-05 SECTION 13.3.1, EQUATIONS 13.3-1, 13.3-2 & 13.3-3, WHERE $S_{DS} = 1.93$, $a_p = 2.5$, $I_p = 1.5$ & $R_p = 2.5$
2. THIS PRE-APPROVAL CONFORMS TO THE 2007 CALIFORNIA BUILDING CODE.
3. THE DETAILS IN THIS PRE-APPROVAL MAY BE USED AT ANY LOCATION IN THE STATE OF CALIFORNIA.
THE ELEVATED FLOOR DETAILS MAY BE USED AT ANY HEIGHT IN A BUILDING.
4. ALL ANCHOR FORCES SHOWN ON THE DRAWINGS ARE WORKING LOADS (AS OPPOSED TO STRENGTH LEVEL LOADS) AND MAY BE USED FOR ALLOWABLE STRESS DESIGN.
5. PER CAN 2-1708A.5, THIS UNIT DOES NOT REQUIRE "SPECIAL SEISMIC CERTIFICATION".

RESPONSIBILITIES OF THE STRUCTURAL ENGINEER OF RECORD

6. DESIGN BACKING BARS, STUDS, ETC. WHICH THE UNITS ARE ATTACHED TO AS NOTED ON THE DRAWINGS.
THE SEOR SHALL ALSO VERIFY THE ADEQUACY OF THE STRUCTURES (SUCH AS WALLS AND FLOORS) WHICH SUPPORT THE UNITS FOR THE LOADS IMPOSED ON THEM BY THE UNITS AS WELL AS ALL OTHER LOADS.
7. PROVIDE ANY SUPPORTING STRUCTURE REQUIRED TO SUPPORT WEIGHTS AND FORCES SHOWN, IN ADDITION TO ALL OTHER LOADS.
8. VERIFY THAT THE INSTALLATION IS IN CONFORMANCE WITH THE 2007 CBC AND WITH THE DETAILS SHOWN IN THIS PRE-APPROVAL.
VERIFY THAT THE ACTUAL EQUIPMENT'S WEIGHT, CG LOCATION, ANCHOR LOCATIONS, ANCHOR DETAILS AND THE MATERIAL AND GAGE OF THE UNIT WHERE ATTACHMENTS ARE MADE AGREE WITH THE INFORMATION SHOWN ON THE PRE-APPROVAL DOCUMENTS.

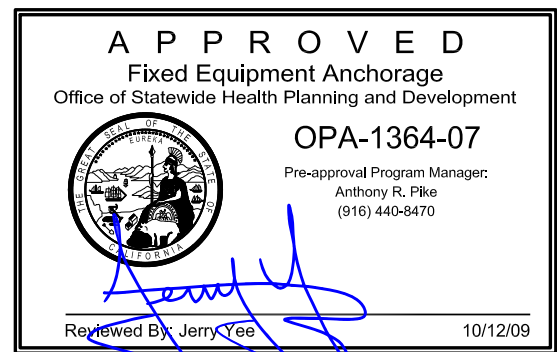

MILESTONE AV TECHNOLOGIES

CHIEF - CMA - 110 PROJECTOR MOUNT

DES. **R. LA BRIE**

EASE JOB NO. **11-0781**

DATE **10/12/09**

SHEET

2

OF **3** SHEETS

SEISMIC ANCHORAGE

CEILING MOUNTED

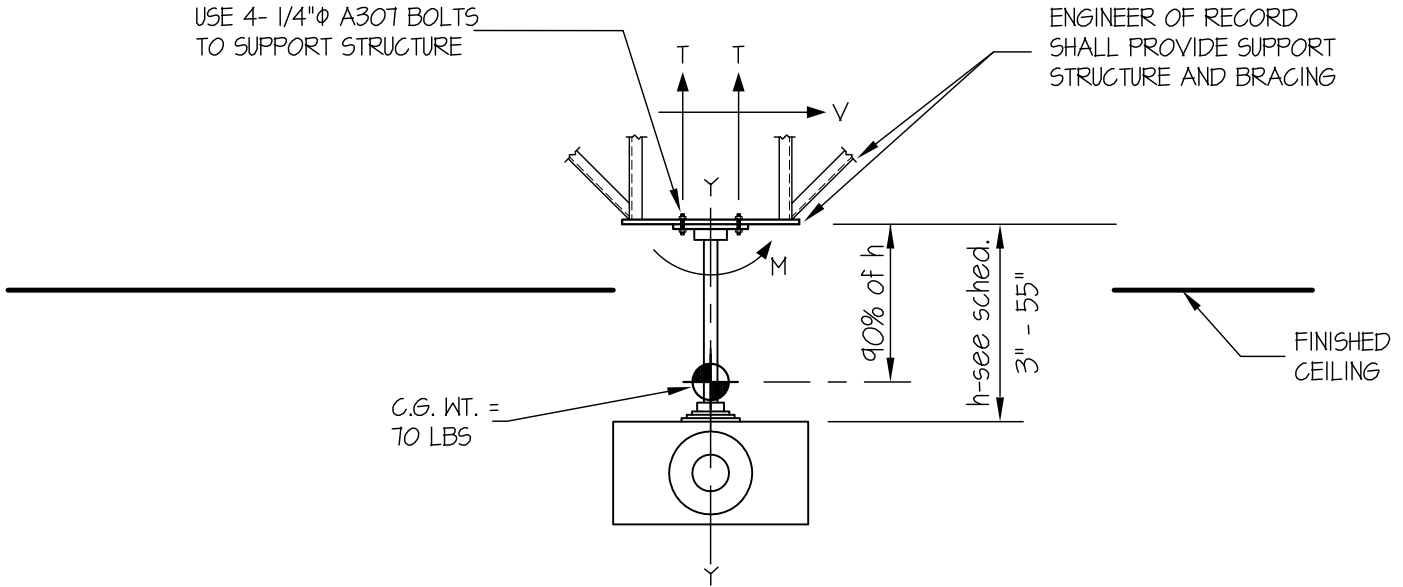

ELEVATION

NOTES:

- ANCHORAGE DESIGN PER 2007 CALIFORNIA BUILDING CODE - SECTION 1613A AND ASCE 7-05 SECTIONS 12 AND 13. ALLOWABLE STRESS DESIGN IS USED.
HORIZONTAL FORCE (E_h) = $2.43 W_p (S_{DS} = 1.93, I_p = 1.5, a_p = 2.5, R_p = 2.5)$
VERTICAL FORCE (E_v) = $0.2T W_p$
- CENTER OF GRAVITY (C.G.) WEIGHT IS A MAXIMUM. THIS PRE-APPROVAL ENCOMPASSES ALL WEIGHTS UP TO THE MAXIMUM WEIGHT SHOWN.
- ARCHITECT OR STRUCTURAL ENGINEER OF RECORD SHALL PROVIDE SUPPORT STRUCTURE TO SUPPORT WEIGHTS AND FORCES SHOWN.
- SEE GENERAL NOTES: SHEET 1



APPROVED
Fixed Equipment Anchorage
Office of Statewide Health Planning and Development

OPA-1364-07

Pre-approval Program Manager:
Anthony R. Pike
(916) 440-8470

Reviewed By: Jerry Yee *Jerry Yee* 10/12/09

MILESTONE AV TECHNOLOGIES

CHIEF - CMA - 110 PROJECTOR MOUNT

DES. **R. LA BRIE**

EASE JOB NO. **11-0781**

DATE **10/12/09**

SHEET
3

OF **3** SHEETS

SEISMIC ANCHORAGE

CEILING MOUNTED

USE 4- 1/4"φ A307 BOLTS
TO SUPPORT STRUCTURE

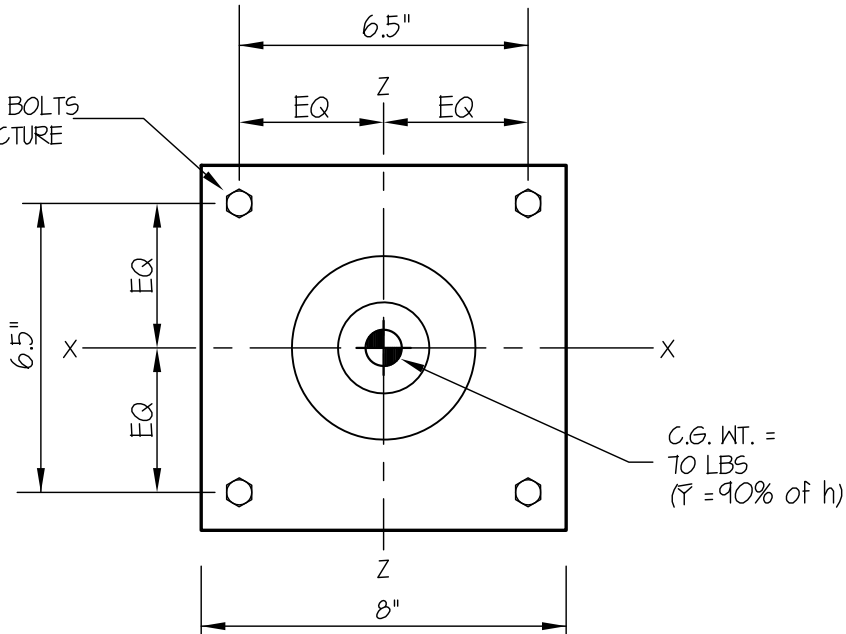

PLAN AT CEILING PLATE

Drop Tube (h)	Moment inch-lbs	Tension lbs/bolt	Shear lbs/bolt
12"	1836	228	43
24"	3672	434	43
36"	5508	641	43
48"	7344	847	43
55" (MAX)	8415	967	43



MILESTONE AV TECHNOLOGIES

CHIEF - CMA - 110 PROJECTOR MOUNT

DES. **R. LA BRIE**

EASE JOB NO. **11-0781**

DATE **10/12/09**

SHEET

1

OF **2** SHEETS

SEISMIC ANCHORAGE

CEILING MOUNTED

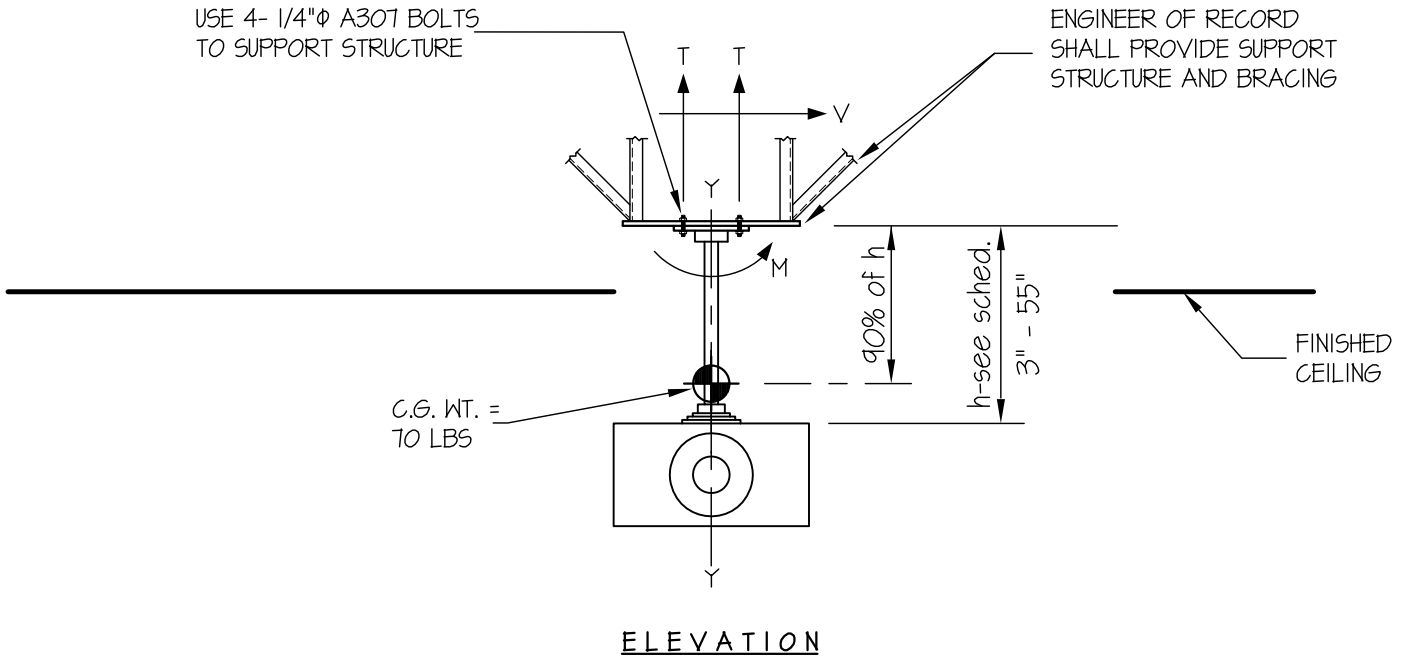

NOTES:

1. FORCES ARE DETERMINED PER 2007 CALIFORNIA BUILDING CODE SECTION 1613A AND ASCE 7-05 SECTIONS 12 AND 13. ALLOWABLE STRESS DESIGN IS USED.

HORIZONTAL FORCE (E_h) = $2.43 W_p$ ($S_{DS} = 1.93, a_p = 2.5, I_p = 1.5, R_p = 2.5$)

VERTICAL FORCE (E_v) = $0.27 W_p$

2. CENTER OF GRAVITY (C.G.) WEIGHT IS A MAXIMUM. THIS CALCULATION ENCOMPASSES ALL WEIGHTS UP TO THE MAXIMUM WEIGHT SHOWN.

3. ARCHITECT OR STRUCTURAL ENGINEER OF RECORD SHALL PROVIDE SUPPORT STRUCTURE TO SUPPORT WEIGHTS AND FORCES SHOWN.



MILESTONE AV TECHNOLOGIES

CHIEF - CMA - 110 PROJECTOR MOUNT

DES. **R. LA BRIE**

EASE JOB NO. **11-0781**

DATE **10/12/09**

SHEET

2

OF **2** SHEETS

SEISMIC ANCHORAGE

CEILING MOUNTED

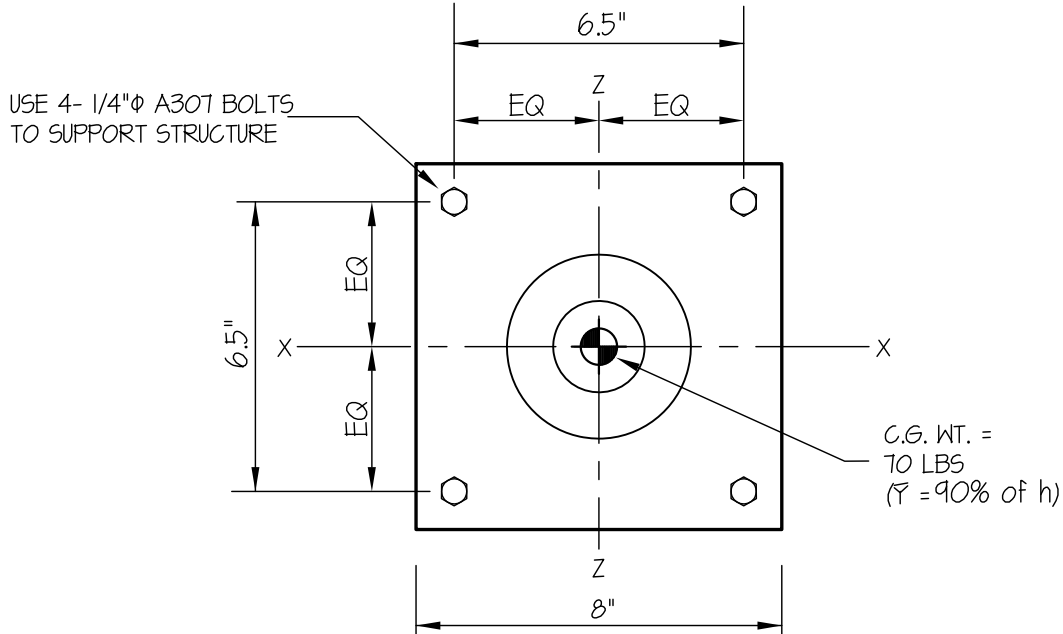

PLAN AT CEILING PLATE

Drop Tube (h)	Moment inch-lbs	Tension lbs/bolt	Shear lbs/bolt
12"	1836	228	43
24"	3672	434	43
36"	5508	641	43
48"	7344	847	43
55" (MAX)	8415	967	43

LOADS:

WEIGHT = 70 LBS (INCLUDES PROJECTOR)

HORIZONTAL FORCE (E_h) = 170 LBS

VERTICAL FORCE (E_v) = 19 LBS

BOLT GROUP PROPERTIES:

$I_{x-x} = 40 \text{ in.}^4$

$I_{z-z} = 40 \text{ in.}^4$

$I_{y-y} = 81 \text{ in.}^4$

MOMENTS:

$M_{xx} = 170\#(49.5") = 8415"\#$

$M_{zz} = 170\#(49.5") = 8415"\#$

$M_{yy} = 170\#(0") = 0"\#$

BOLT FORCES:

TENSION (T)

$T = \frac{8415"\#(4.49")}{40} + \frac{70\# + 19\#}{4 \text{ BOLTS}} = 967 \text{ LBS/BOLT (MAX)}$

SHEAR (V)

$V = \frac{170\#}{4 \text{ BOLTS}} = 43 \text{ LBS/BOLT (MAX) (PER AISC J3.7, LESS THAN 20% STRESS)}$