

THE INFORMATION AND DESIGNS CONTAINED IN THIS DRAWING ARE CONFIDENTIAL AND THE PROPRIETARY PROPERTY OF MILESTONE AV TECHNOLOGIES NEITHER THIS DESIGN NOR ANY INFORMATION CONTAINED IN THIS DRAWING MAY BE REPRODUCED OR DISCLOSED TO OTHERS WITHOUT THE EXPRESS WRITTEN CONSENT OF MILESTONE AV TECHNOLOGIES.

| | | | | | | |
|--|-----|------------|---------------------------------|-------------|---|--|
| CAD GENERATED DRAWING, DO NOT MANUALLY UPDATE. | | | | | 6436 CITY WEST PKWY EDEN PRAIRIE MN, 55344 PHONE: 866-977-3901 FAX: 877-894-6918 | |
| DRAWN BY | JAB | 10/25/2019 | DESCRIPTION | | | |
| ENG APPROVAL | | | LED, ABSEN ACCLAIM PLUS, 2 HIGH | | | |
| MFG APPROVAL | | | MODEL NO. | | | |
| QA APPROVAL | | | TILX2AP | | | |
| SHEET 1 OF 3 | | SCALE | SIZE | DWG. NO. | REV. | |
| | | 1:6 | B | TECH-001027 | 00 | |

SHOWN WITH ABSEN ACCLAIM PRO, PLUS

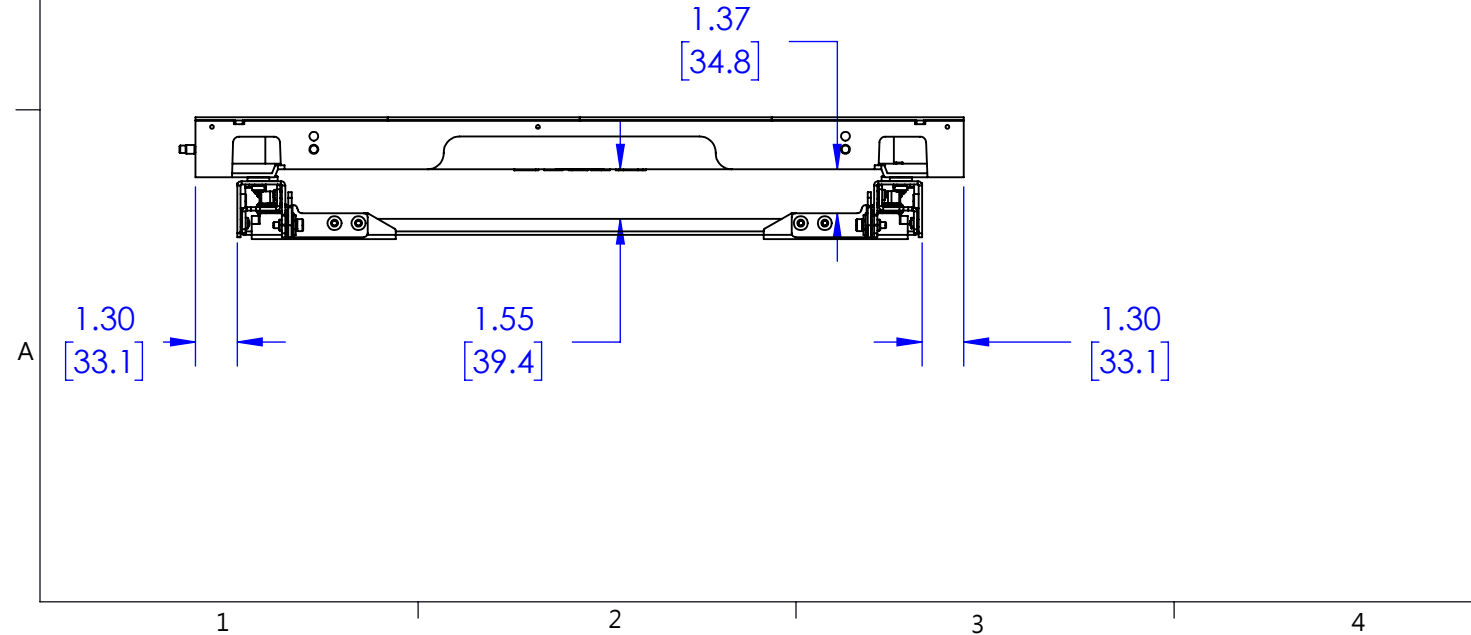
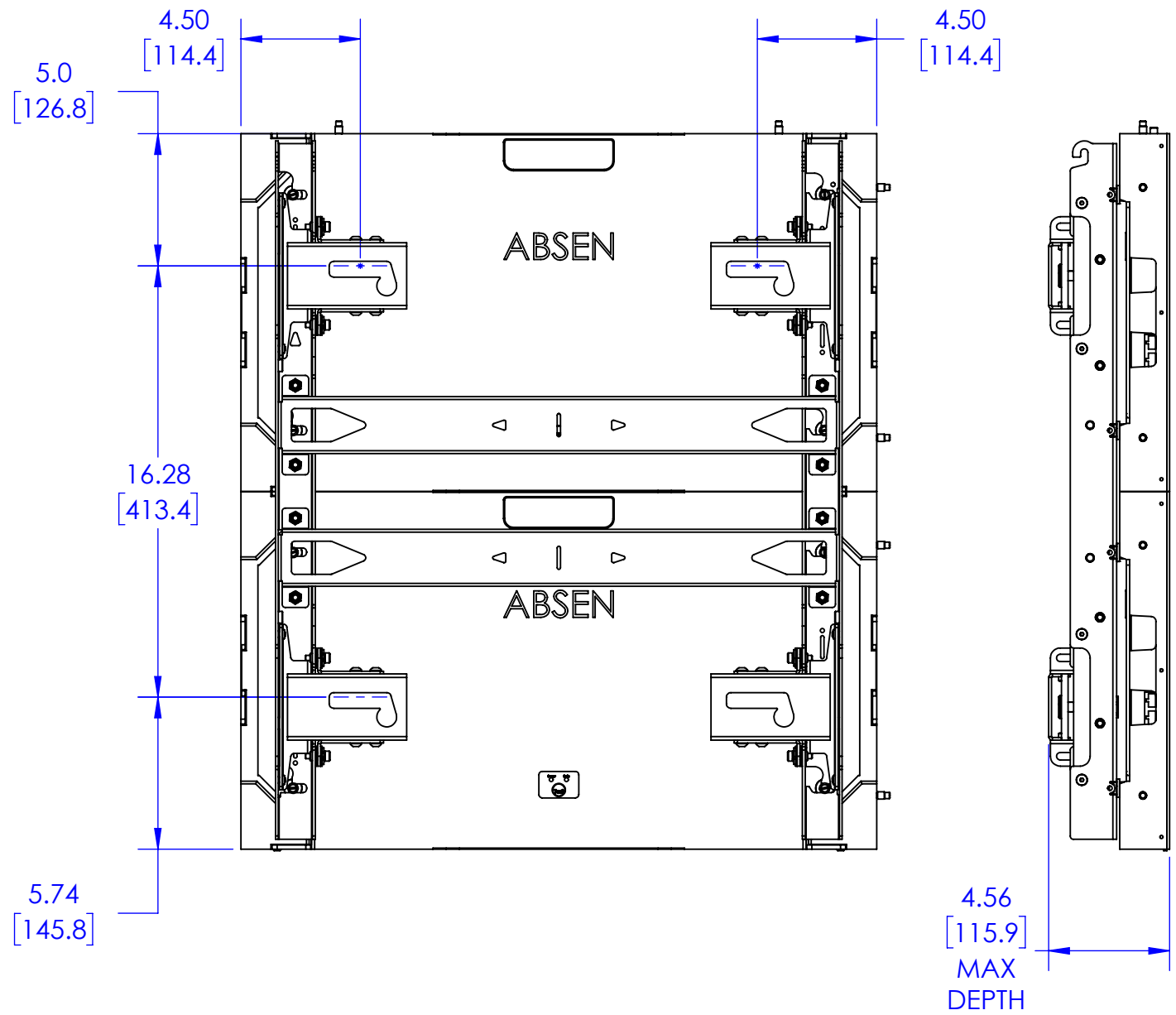
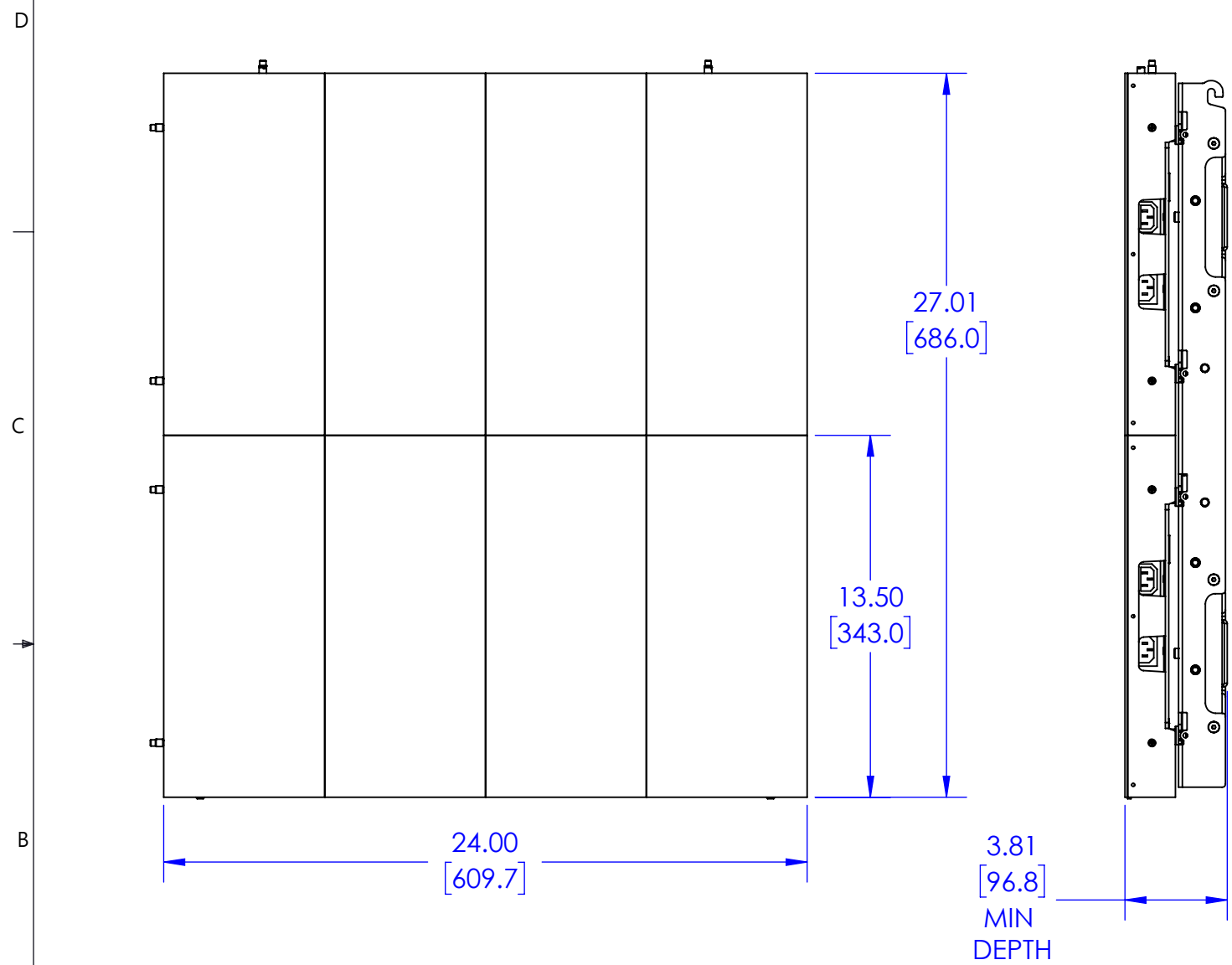

THE INFORMATION AND DESIGNS CONTAINED IN THIS DRAWING ARE CONFIDENTIAL AND THE PROPRIETARY PROPERTY OF MILESTONE AV TECHNOLOGIES NEITHER THIS DESIGN NOR ANY INFORMATION CONTAINED IN THIS DRAWING MAY BE REPRODUCED OR DISCLOSED TO OTHERS WITHOUT THE EXPRESS WRITTEN CONSENT OF MILESTONE AV TECHNOLOGIES.

| | | |
|--|----------------|---|
| CAD GENERATED DRAWING, DO NOT MANUALLY UPDATE. | | <p>6436 CITY WEST PKWY EDEN PRAIRIE MN, 55344 PHONE: 866-977-3901 FAX: 877-894-6918</p> |
| DRAWN BY | JAB 10/25/2019 | |
| ENG APPROVAL | | DESCRIPTION |
| MFG APPROVAL | | LED, ABSEN ACCLAIM PLUS, 2 HIGH |
| QA APPROVAL | | MODEL NO. |
| | | TIL1X2AP |
| SHEET 2 OF 3 | SCALE 1:6 | SIZE DWG. NO. TECH-001027 |
| | | REV. 00 |

SHOWN WITH ABSEN ACCLAIM

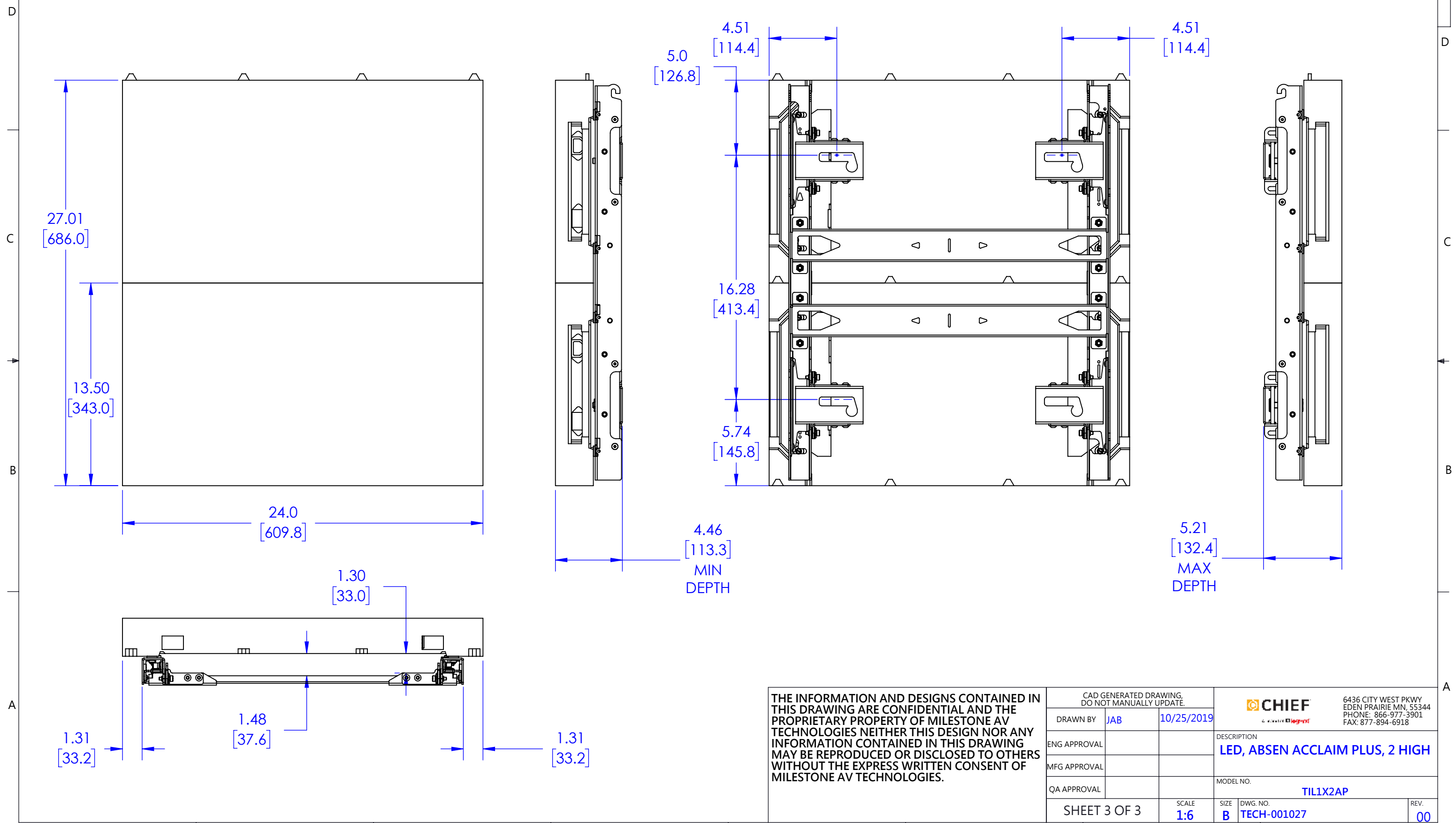

THE INFORMATION AND DESIGNS CONTAINED IN THIS DRAWING ARE CONFIDENTIAL AND THE PROPRIETARY PROPERTY OF MILESTONE AV TECHNOLOGIES NEITHER THIS DESIGN NOR ANY INFORMATION CONTAINED IN THIS DRAWING MAY BE REPRODUCED OR DISCLOSED TO OTHERS WITHOUT THE EXPRESS WRITTEN CONSENT OF MILESTONE AV TECHNOLOGIES.

| | | | | | | |
|--|-----|------------|---------------------------------|-------------|---|------|
| CAD GENERATED DRAWING, DO NOT MANUALLY UPDATE. | | | | | 6436 CITY WEST PKWY EDEN PRAIRIE MN, 55344 PHONE: 866-977-3901 FAX: 877-894-6918 | |
| DRAWN BY | JAB | 10/25/2019 | DESCRIPTION | | | |
| ENG APPROVAL | | | LED, ABSEN ACCLAIM PLUS, 2 HIGH | | | |
| MFG APPROVAL | | | MODEL NO. | | | |
| QA APPROVAL | | | TILX2AP | | | |
| SHEET 3 OF 3 | | SCALE | 1:6 | SIZE | DWG. NO. | REV. |
| | | | B | TECH-001027 | | 00 |