

# FULLVISION

Fixed frame projection screen for wall installations

**DA-LITE**  
A brand of **legrand**

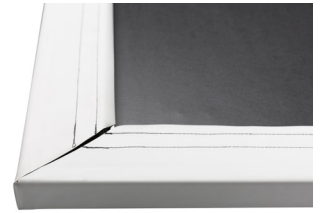

## Product specifications:

- Fixed frame, full wrap around, projection screen with an aluminum frame.
- Fixed frame wrap-around projection screen available up to 4 meter height and 6 meter width.
- Low-profile installation of only 3 cm deep
- The aluminum frame is finished with a matte white powder coating.
- Innovative and easy upright projection surface attachment for installations with limited work space.
- The aluminum frame parts are connected in the corners with rigid steel corners.
- The projection screen surface is attached to the rear of the screen with Velcro®.
- Easy and completely flush wall installation by hanging the screen over two screws by using the supplied mounting brackets.
- Option to hang screen with cables from the ceiling using the same brackets.
- Lightweight aluminum frame that will not bend, even on the widest screen
- Standard high resolution projection surface offering
- Innovative 3 step corner covering with projection surface that prevents wrinkling.
- Easy transportable in robust but lightweight packaging.

## Aspect Ratios:

16:10

16:9

## Available dimensions

Minimum width: 200 cm

Maximum width:

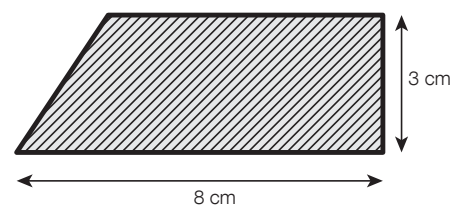
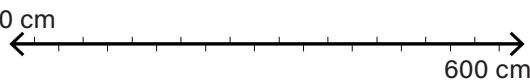

	Viewing Area	Nominal Diagonal		Frame dimensions		Net weight
	cm	cm	inches	Frame height	Frame width	cm
16:10	125 x 200	236	93"	125	200	11
	137 x 220	259	102"	137	220	12
	150 x 240	283	111"	150	200	12
	175 x 280	330	130"	175	280	13
	187 x 300	353	139"	187	300	14
	219 x 350	413	163"	219	350	29
	250 x 400	482	186"	250	400	33
	281 x 450	531	209"	281	450	35
	313 x 500	590	232"	313	500	41
	344 x 550	648	255"	344	550	45
	375 x 600	707	278"	375	600	49
16:9	112 x 200	229	90"	112	200	11
	124 x 220	249	98"	124	220	12
	135 x 240	269	108"	135	240	12
	157 x 280	320	126"	157	280	13
	169 x 300	345	136"	169	300	29
	197 x 350	402	158"	197	350	29
	225 x 400	467	184"	225	400	33
	253 x 450	524	206"	253	450	35
	281 x 500	574	226"	281	500	41
	309 x 550	631	248"	309	550	45
	338 x 600	688	271"	338	600	49

## Available High Resolution projection surfaces

All screen surfaces are seamless in the viewing area.

**HD** PROGRESSIVE

### HD Progressive 0.6

Gain: 0.6  
Viewing Angle: 170°  
Base material: Vinyl  
Fire retardancy: B2  
Black backing: Yes  
Opacity rating: > 99 %  
Seamless: Yes  
GreenGuard certification: Yes



**Standard:** UL 2818 - 2013 Standard for Chemical Emissions for Building Materials, Finishes and Furnishings

**Certification number**

Greenguard - 11065-410

Greenguard Gold - 11065-420

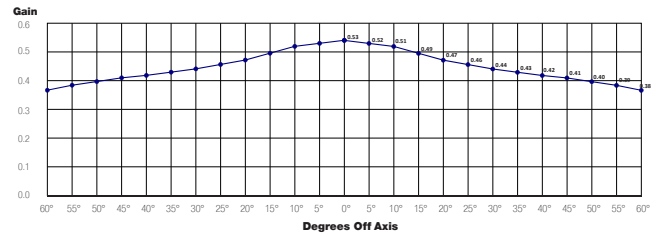

### HD Progressive 0.9

Gain: 0.9  
Viewing Angle: 170°  
Base material: Vinyl  
Fire retardancy: B2  
Black backing: Yes  
Opacity rating: > 99 %  
Seamless: Yes  
GreenGuard certification: Yes



**Standard:** UL 2818 - 2013 Standard for Chemical Emissions for Building Materials, Finishes and Furnishings

**Certification number**

Greenguard - 11066-410

Greenguard Gold - 11066-420

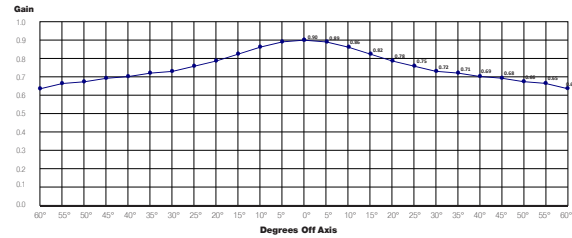

### HD Progressive 1.1

Gain: 1.1  
Viewing Angle: 170°  
Base material: Vinyl  
Fire retardancy: B2  
Black backing: Yes  
Opacity rating: > 99 %  
Seamless: Yes  
GreenGuard certification: Yes



**Standard:** UL 2818 - 2013 Standard for Chemical Emissions for Building Materials, Finishes and Furnishings

**Certification number**

Greenguard - 11067-410

Greenguard Gold - 11067-420

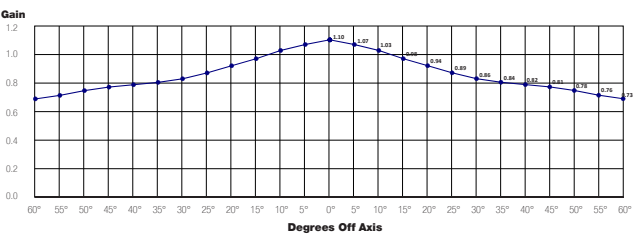

### HD Progressive 1.3

Gain: 1.3  
Viewing Angle: 150°  
Base material: Vinyl  
Fire retardancy: B2  
Black backing: Yes  
Opacity rating: > 99 %  
Seamless: Yes  
GreenGuard certification: Yes



**Standard:** UL 2818 - 2013 Standard for Chemical Emissions for Building Materials, Finishes and Furnishings

**Certification number**

Greenguard - 42729-410

Greenguard Gold - 42729-420

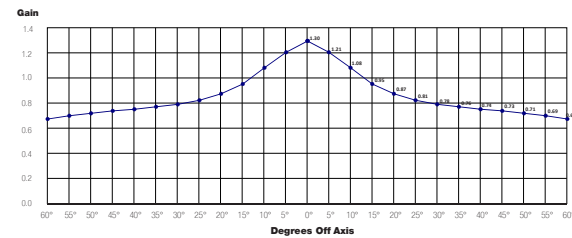

## Available standard resolution projection surfaces

All screen surfaces are seamless in the viewing area.

### Matte White

Gain: 1.0  
Viewing Angle: 120°  
Base material: Vinyl  
Fire retardancy: B2  
GreenGuard certification: Yes



B1/M1 certified projection surface is optional in Matte White on request.

## Certifications

- Products are manufactured in an ISO14001 certified facility
- Projecta is an ISO 9001 certified company
- REACH - Registration, Evaluation, Authorisation and Restriction of Chemical substances.
- RoHS - Restriction of Hazardous Substances.
- WEEE - Waste Electronic and Electrical Equipment Regulations.

## Customisation

Give exact the sizes of the projection screen you need:

Viewing size: \_\_\_\_\_ Height (cm.) x \_\_\_\_\_ width (cm.)

Surface: \_\_\_\_\_

Remarks: \_\_\_\_\_

## Dimensions and installation

Top frame positioning

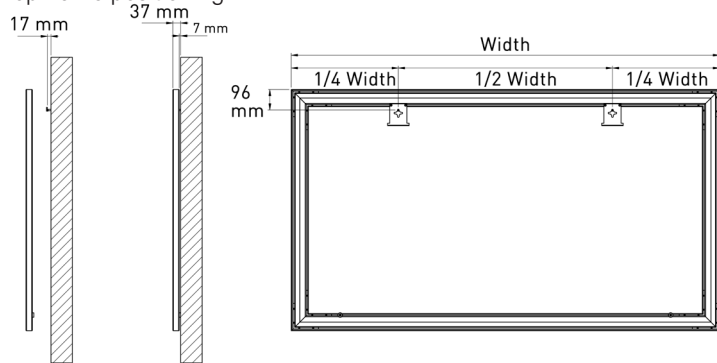

Side frame positioning (screens smaller than 400 cm wide)

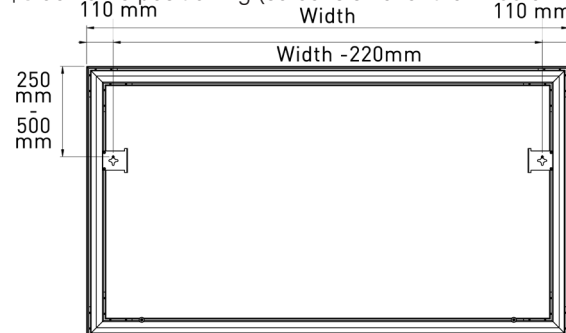

Rotate brackets for flying the projection screen

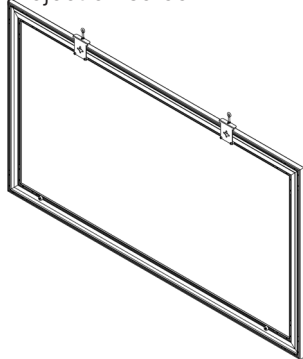

Attach projection surface upright to save space

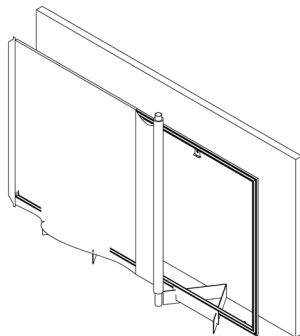

Clean corner finish, without wrinkling

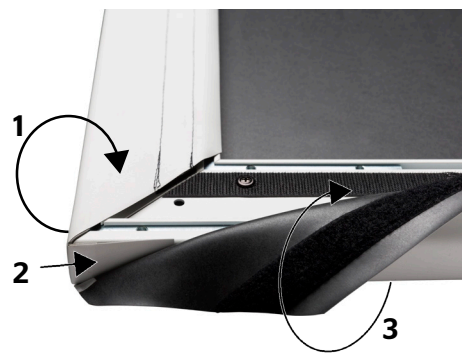

## Warranty

Da-Lite provides a limited 5 year warranty on the Elpro Concept range and a limited 2 year warranty on all other products. The warranty on the motor of electrical screens is 5 year. All warranties are in effect beginning the date the product was invoiced by Projecta.