ASSEMBLY INSTRUCTIONS FOR
Base Plate Cart BPC-46



Base Plate Cart BPC-46

CAUTION!

The user of this product should exercise caution when using the Base Plate Cart. The cart should always be pushed, never pulled, by the user.

Tools Required

7/16" wrench, Phillips screwdriver

Procedure

1. Remove contents from carton and examine.
2. Bolt the Spacers to the cart to act as stops for the base plates. See Figure 1.

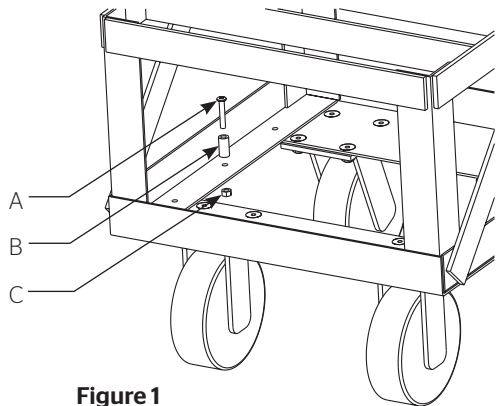

Figure 1

	Qty.	Description
A	6	Screw, 1/4"-20 x 1-1/2"
B	6	Spacer
C	6	Nut, hex 1/4"-20



A Milestone AV Technologies Brand

3100 North Detroit Street
Warsaw, Indiana 46582
P: 574.267.8101 or 800.622.3737
F: 574.267.7804 or 877.325.4832
E: info@da-lite.com
www.da-lite.com

DL-0378 06.14

© 2014 Milestone AV Technologies LLC. Printed in U.S.A.

E-432