



---

INSTRUCTION BOOK FOR  
Contour® Electrol®

---



# Original Instructions

## Disclaimer

---

Legrand AV and its affiliated corporations and subsidiaries, intend to make this manual accurate and complete. However, Legrand AV makes no claim that the information contained herein covers all details, conditions or variations, nor does it provide for every possible contingency in connection with the installation or use of this subject to change without notice or obligation of any kind. Legrand AV makes no representation of warranty, expressed or implied, regarding the information contained herein. Legrand AV assumes no responsibility for accuracy, completeness or sufficiency of the information contained in this document.

Da-Lite® is a registered trademark of Legrand AV Inc. All rights reserved.

## Important Safety Instructions

---

When using your video equipment, basic safety precautions should always be followed, including the following:

1. Read and understand all instructions before using.
2. Maximum surrounding air temperature 122°F (50°C).
3. Main disconnect must be incorporated in the fixed wiring in accordance with the wiring rules.
4. Rated for indoor use only.
5. Use copper rated conductors rated 167°F (75°C) or higher.
6. If the supply cord is damaged, it must be replaced by the manufacturer, its service agent or similarly qualified persons in order to avoid hazard.
7. Supplied drive is only intended for use in Da-Lite screen models Advantage, Contour, and Cosmopolitan.
8. Position the cord so that it will not be tripped over, pulled, or contact hot surfaces.
9. If an extension cord is necessary, a cord with a current rating at least equal to that of the appliance should be used. Cords rated for less amperage than the appliance may overheat.
10. To reduce the risk of electric shock, do not disassemble this appliance. Contact an authorized service dealer when repair work is required. Incorrect reassembly can cause electric shock when the appliance is used subsequently.
11. The use of an accessory attachment not recommended by the manufacturer may cause a risk of fire, electric shock, or injury to persons.
12. Failure to provide adequate structural strength for this component can result in serious personal injury or damage to equipment! It is the installer's responsibility to make sure the structure to which this component is attached can support the weight of all equipment. Reinforce the structure as required before installing the component.
13. Use this projection screen only for its intended use as described in these instructions. Do not use attachments not recommended by the manufacturer.

### Save These Instructions

## Pre-Installation

---

1. Carefully unpack screen and remove outer wrapping from case.
2. Set aside the Installation Kit. Items inside will be used during installation.

## Tools Required for Installation

---

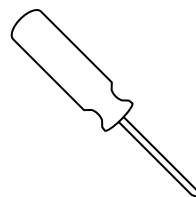

#2 Phillips Screwdriver

# Installation

**NOTE:** Remove the black tape and rubber bands from the slat bar after the case has been installed.

There are three ways to install the Contour Electrol – Wall Mount, Ceiling Mount, or Ceiling Hook. Procedures for each method are as follows:

## Wall Mount

1. Using a #2 Phillips screwdriver, loosen the two stop screws and remove the wall mount bracket from the back side of the case (Figure 1).

**NOTE:** The ceiling flush mount and ceiling hook mount brackets are attached to the top side of the case. These brackets are not necessary for wall mounting and can be removed at this time.

2. Secure the wall mount bracket to the wall at the desired height. The wall mount bracket should be fastened to the wall studs or some reinforcement within the wall. Concrete or brick walls require special fasteners and anchors. Allow at least 2-3/8" above the wall mount bracket to be able to position the case on the bracket (Figure 2).
3. Make sure the bracket is level.
4. Hang the screen case on the wall mount bracket as shown in (Figure 2). Be sure the case is fully seated on the bracket.
5. Tighten the two stop screws against the wall mount bracket using a #2 Phillips screwdriver (Figure 1).

## Ceiling Flush Mount

1. The ceiling hook brackets are attached to the top side of the housing. They must be removed prior to ceiling flush mount.

**NOTE:** Do not remove the wall mount bracket, even if you are not using it for mounting. This provides structural stability to the case.

2. Using a #2 Phillips screwdriver, loosen the four 1/4"x 5/8" screws holding the ceiling flush mount brackets (Figure 3).
3. Slide the ceiling flush mount brackets so that the mounting holes extend beyond the ends of the case. All four 1/4"x 5/8" screws must remain within the channels.
4. Tighten the four 1/4"x 5/8" screws holding the ceiling flush mount brackets (Figure 3).
5. Before mounting your Contour Electrol, be sure the ceiling has adequate reinforcement.
6. Hold the screen case up to the ceiling and mark the hole locations. The brackets have a set of front holes and a set of rear holes. Attach the Contour Electrol using the appropriate hardware for your ceiling type. It is best to use at least one hole in each set.

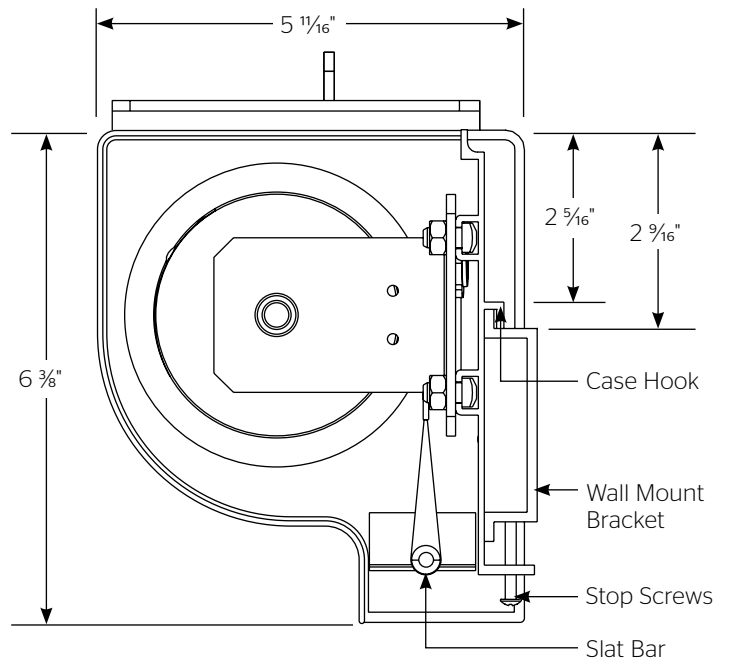

Figure 1

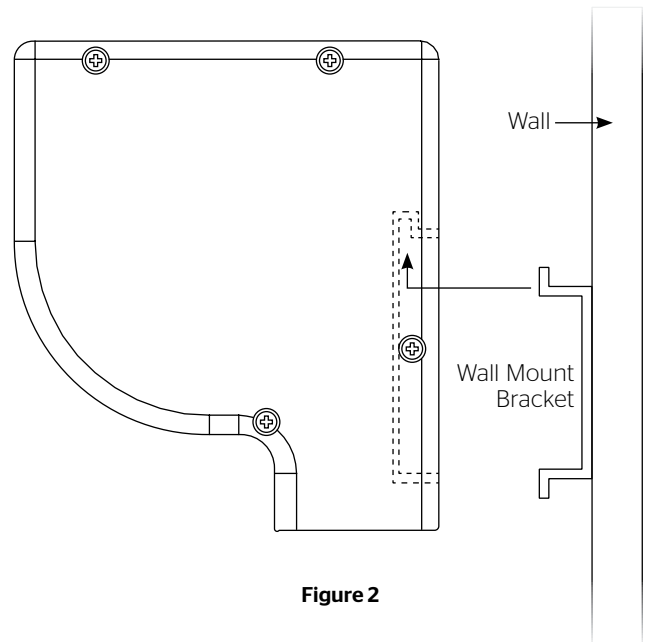

Figure 2

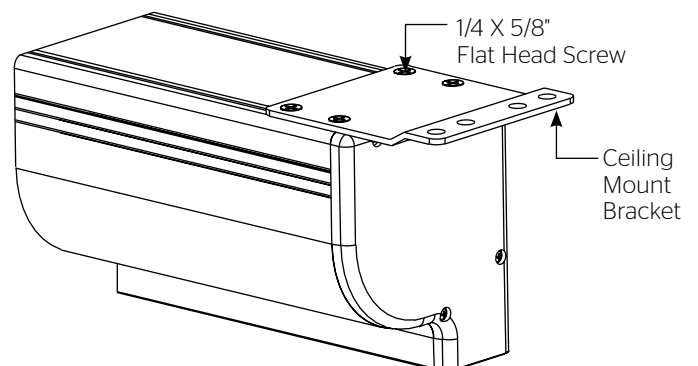

Figure 3

## Installation (continued)

### Ceiling Hook Mount

1. The ceiling hook mount brackets are tied together and attached to the ceiling flush mount bracket at one end of the case. Remove the ceiling hook mount brackets.
2. Remove the ceiling flush mount brackets using a #2 Phillips screwdriver (Figure 3). Retain four 1/4" x 5/8" screws.  
**NOTE:** Do not remove the wall mount bracket, even if you are not using it for mounting. This provides structural stability to the case.
3. The top of the screen case has two channels with threaded nuts that slide the length of the case. Attach the two ceiling hook mount brackets using the 1/4" x 5/8" screws and threaded nuts, two per bracket. The brackets can be attached anywhere within 12" of the ends of the case (Figure 4).
4. Before hanging your Contour Electrol, be sure the ceiling has adequate reinforcement.
5. Using the holes in the ceiling hook brackets, hang the Contour Electrol using the appropriate hardware and fasteners for your ceiling type.

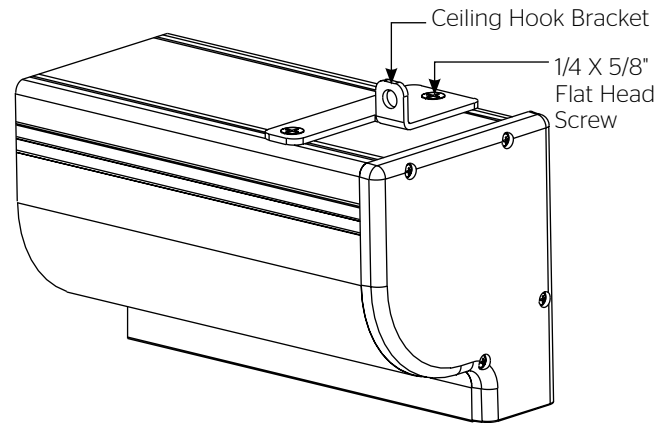

Figure 4

## Electrical Installation

1. Open the junction box on the left end of the case using a #2 Phillips screwdriver. Install electrical connections that apply to your unit. Make sure to review the wiring diagram for proper hook up. Replace the junction box cover.

NOTE: Must be installed in accordance with the requirements of the Local Building Codes, the Canadian Electrical Code (CEC), CAN/CSA C22.1 and the National Electric Code (NEC), NFPA 70.

2. Test installation by running screen up and down a few times. Be prepared to stop screen should any objects obstruct the movement of the screen. To prevent damage to the motor, the standard duty cycle is 1 minute on and 3 minutes off.

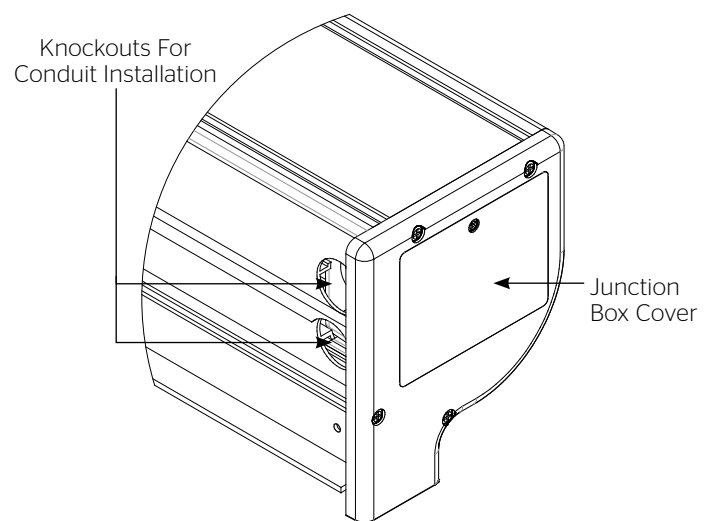
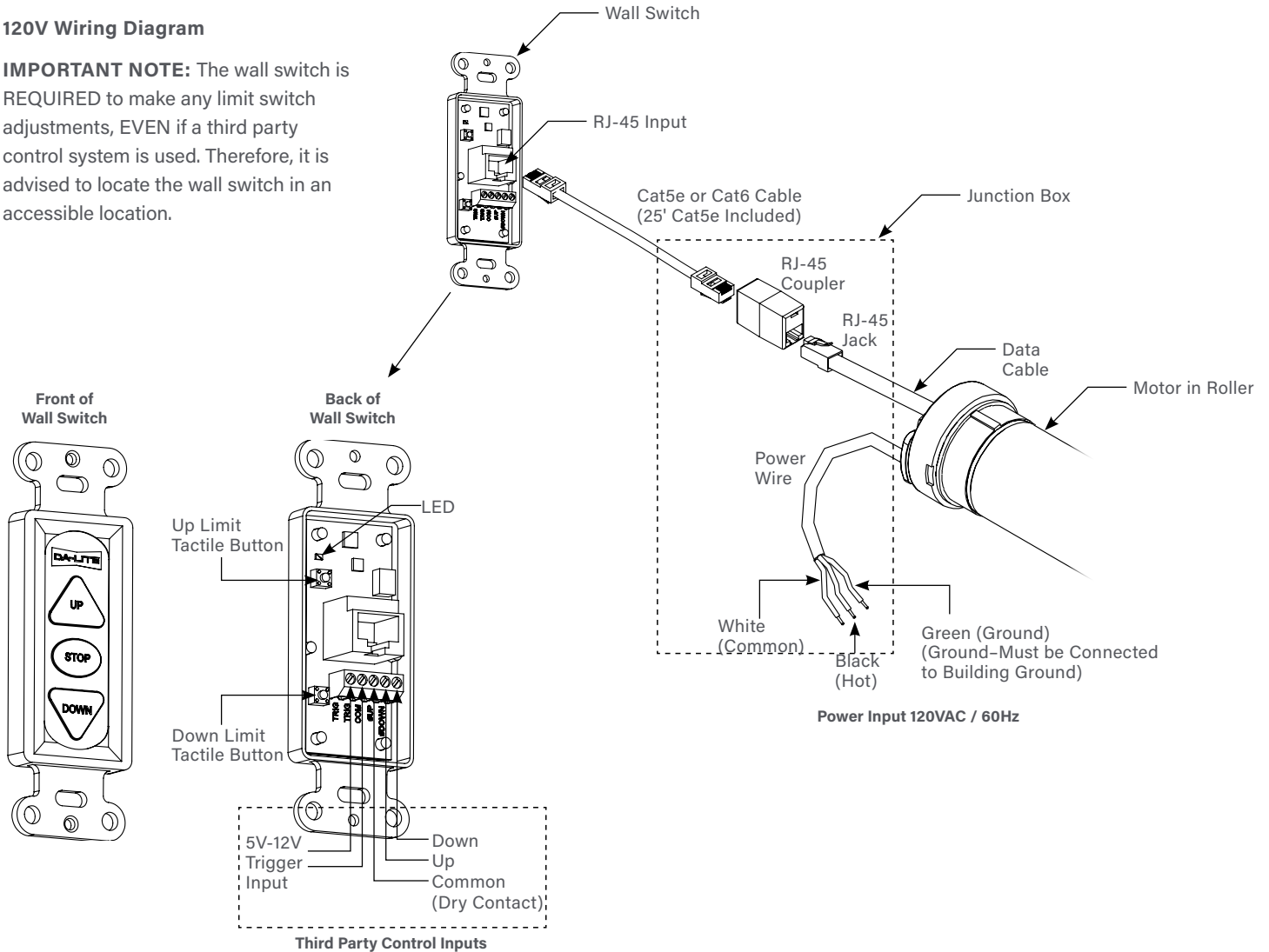

Figure 5

# Contour® Electrol® Installation for 120V Screens

## 120V Wiring Diagram

**IMPORTANT NOTE:** The wall switch is REQUIRED to make any limit switch adjustments, EVEN if a third party control system is used. Therefore, it is advised to locate the wall switch in an accessible location.



## THIRD PARTY CONTROL

### Control Panel

A control panel may be connected to the wall switch by using the dry contact Up, Down and Common connections. The control panel must provide a momentary, dry contact closure of at least 1/2 second.

1. Use 3-conductor 20-24 gauge wire to connect the control panel to the Screen Controller.
2. A momentary closure across the COM and #UP inputs will be an "up" command.
3. A momentary closure across the COM and #DN inputs will be a "down" command.
4. A momentary closure across the COM, #UP and #DN inputs will be a "stop" command.

### Projector Trigger

When a 5-12V signal is received from a projector trigger output (or trigger output from any other device) the screen will move to the down position. When voltage is removed the screen will run to the up position.

Use 2-conductor 18-24 gauge wire to extend the low voltage connection from the 5 to 12-volt trigger output to the TRIG input on the wall switch.

**NOTE:** When extending the low voltage connection from the trigger output polarity does not matter. The wires are interchangeable.

## 230V Wiring Diagram

**IMPORTANT NOTE:** The wall switch is REQUIRED to make any limit switch adjustments, EVEN if a third party control system is used. Therefore, it is advised to locate the wall switch in an accessible location.

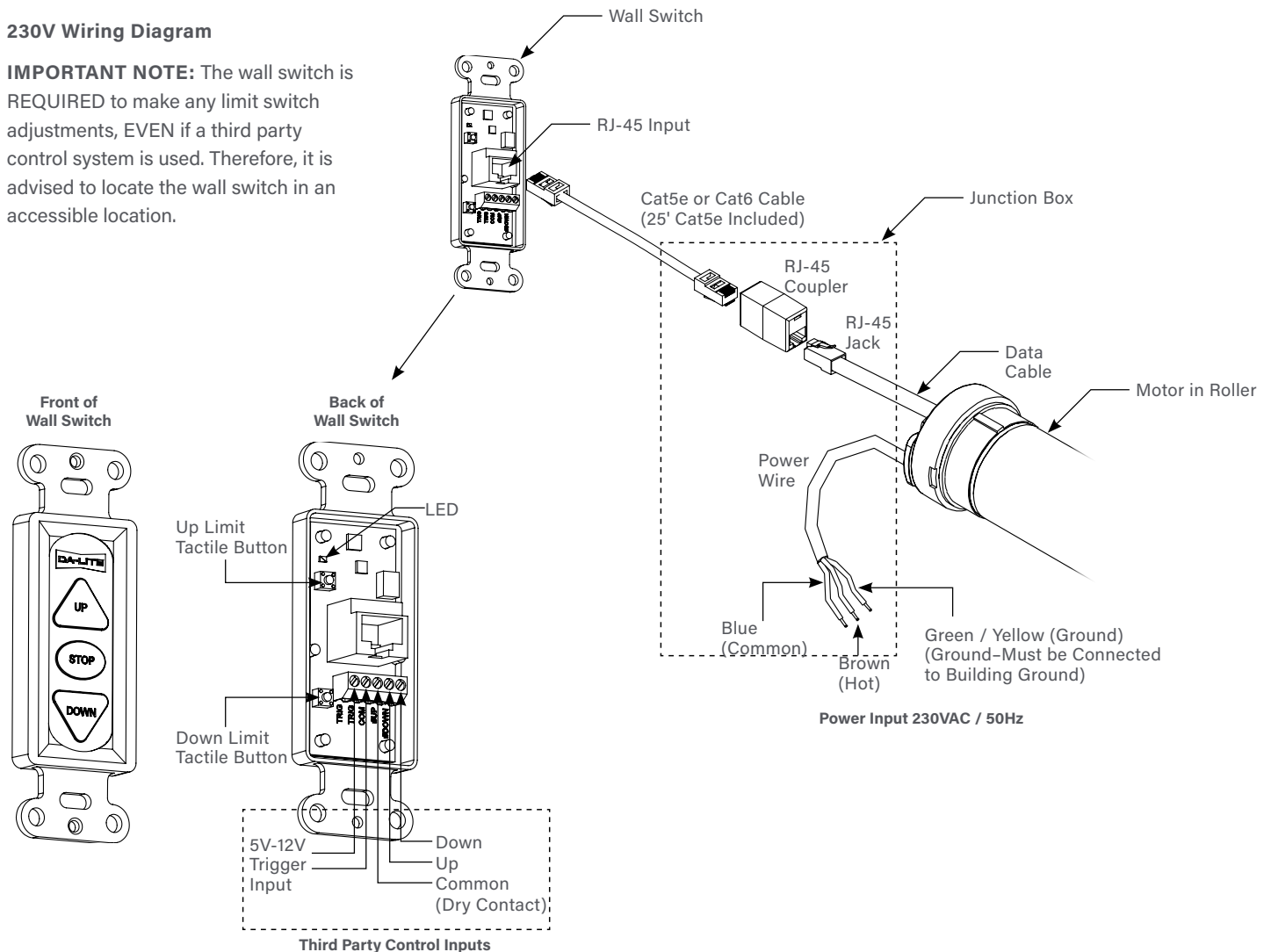

## THIRD PARTY CONTROL

### Control Panel

A control panel may be connected to the wall switch by using the dry contact Up, Down and Common connections. The control panel must provide a momentary, dry contact closure of at least 1/2 second.

1. Use 3-conductor 20-24 gauge wire to connect the control panel to the Screen Controller.
2. A momentary closure across the COM and #UP inputs will be an "up" command.
3. A momentary closure across the COM and #DN inputs will be a "down" command.
4. A momentary closure across the COM, #UP and #DN inputs will be a "stop" command.

### Projector Trigger

When a 5-12V signal is received from a projector trigger output (or trigger output from any other device) the screen will move to the down position. When voltage is removed the screen will run to the up position.

Use 2-conductor 18-24 gauge wire to extend the low voltage connection from the 5 to 12-volt trigger output to the TRIG input on the wall switch.

**NOTE:** When extending the low voltage connection from the trigger output polarity does not matter. The wires are interchangeable.

# Contour® Electrol® Installation for 230V Screens (continued)

## 230V Wiring Diagram with Optional European Style Wall Switch

Use 3-conductor 20–24 gauge wire to connect European style wall switch to the COM, #UP, and #DOWN to the limit adjustment wall switch

**IMPORTANT NOTE:** The European style wall switch is for operation only and CANNOT be used to make limit switch adjustments. Therefore, it is advised to locate the limit adjustment wall switch in an accessible location.

European Style Wall Switch

Limit Adjustment Switch  
(See Previous Page for Wiring to Screen)

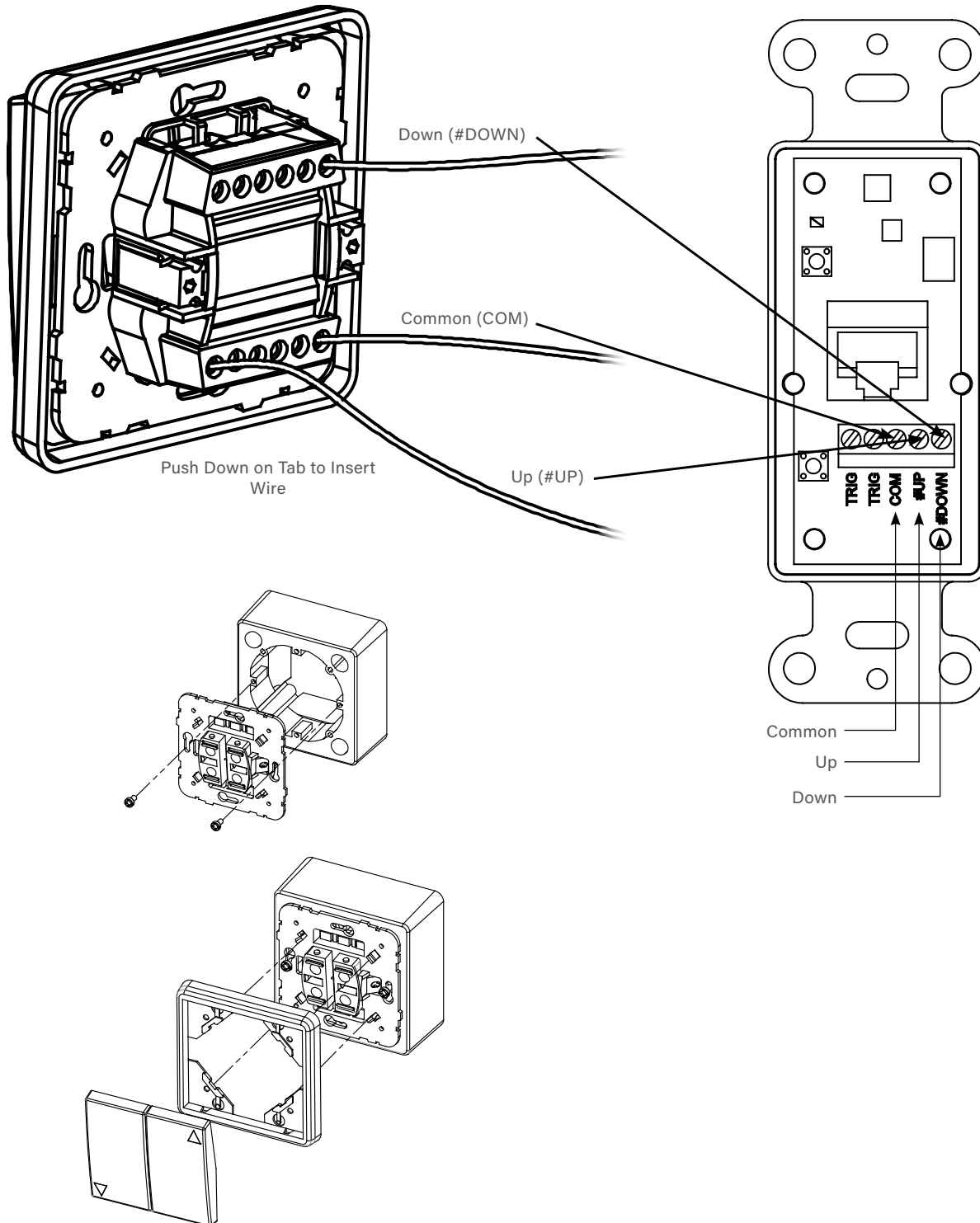

# Screen Adjustment

If your Contour Electrol was ordered as a complete unit, the up and down limits were pre-set by Da-Lite. If your screen and roller assembly was ordered separately from the case, or if general adjustment is needed, please follow the steps below and refer to the Wiring Diagram.

1. Locate the wall switch and remove the cover plate from the 3-button wall switch and remove the switch from the junction box.
2. Locate the two tactile buttons on the back of the switch. They are square silver with black round buttons.
3. To adjust the down limit switch, press and hold the down tactile button until the LED on back of switch turns solid red. This will put the motor in limit set mode. Turn the wall switch over and use the down button on front of switch. Press and hold until the desired travel position is reached. If you travel to far down you can press the up to move the screen upward. If you press and let go of either up or down button the motor will do a small jog in that direction for finer adjustment of screen. Once desired position is reached turn switch over press and hold down tactile button until the LED on back of switch blinks red twice. The down limit is now set.

**NOTE:** If the screen is in limit set mode and no buttons are pushed for 20 seconds, the LED on the back of the wall switch will turn off, the motor will return to run mode and no changes will be saved. If this occurs, return to step 3 for down limit adjustment or step 4 for up limit adjustment.

4. To adjust the up limit switch, press and hold the up tactile button until the LED on back of switch turns solid green. This will put the motor in limit set mode. Turn the wall switch over and use the up button on front of switch. Press and hold until the desired travel position is reached. If you travel to far up you can press the down to move the screen downward. If you press and let go of either up or down button the motor will do a small jog in that direction for finer adjustment of screen. Once desired position is reached turn switch over press and hold up tactile button until the LED on back of switch blinks green twice. The up limit is now set.
5. To test limit switch setting, press and release the up or down button on the wall switch to operate the screen.
6. Replace switch and cover plate on the wall.

**IMPORTANT NOTE:** The wall switch is REQUIRED to make any limit switch adjustments, EVEN if a third party control system is used. Therefore, it is advised to wire the switch or provide a 3-conductor connection that is accessible.

**CAUTION:** Do not adjust for more drop than what was ordered. At least 1-1/2 wraps of fabric must remain on the roller. This screen comes standard with 0" or 2" black at the top. See the specification data sheet for details.

**ATTENTION!** N'effectuez pas de réglage pour obtenir un déroulement supérieur à celui commandé. Au moins 1 à 1/2 tour de toile doit être maintenu sur le cylindre. Cet écran est doté de série d'une bande noire supérieure de 0 cm (0 po) ou 5 cm (2 po). Consultez la fiche technique pour plus de renseignements.

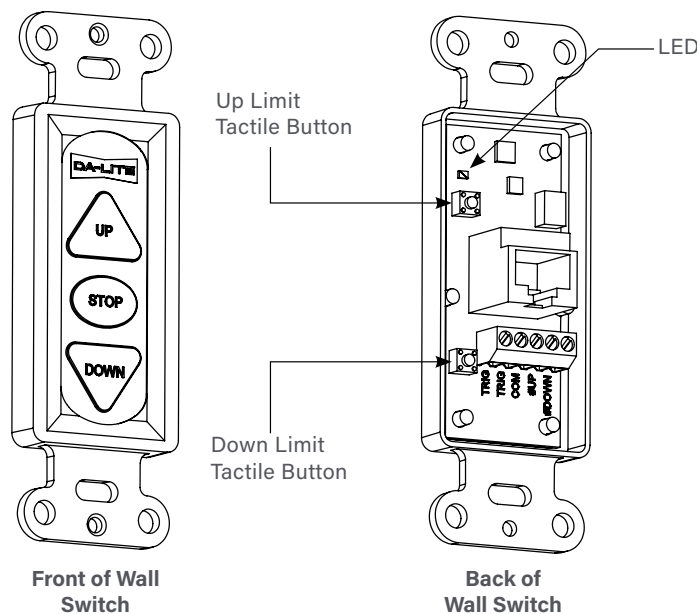



# Operation of Screen

## Operation & Limit Adjustment Wall Switch

1. Press "DOWN" button on screen switch and screen will deploy out of case in downward direction.
2. Press "STOP" button on screen switch and screen will stop if in movement.
3. Press "UP" button on screen switch and screen will retract upward into case.

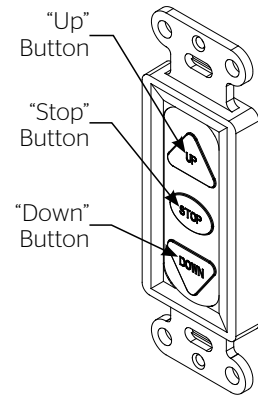

## European Style Wall Switch (230V models only)

1. Press "DOWN" button on screen switch and screen will deploy out of case in downward direction.
2. Press "UP" button on screen switch and screen will retract upward into case.

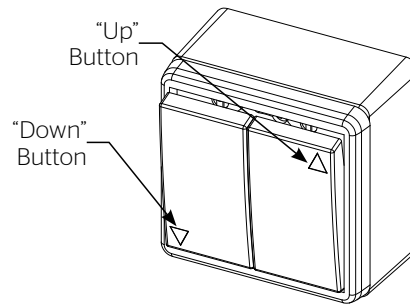

# Troubleshooting

Symptom	Cause	Solution
Screen will not operate and motor does not hum.	Incorrect line voltage.	Verify 115-125V (or 220-240V). If insufficient voltage, rewire incoming electric line.
	Blown fuse.	Replace fuse.
	Tripped circuit breaker.	Reset circuit breaker.
	No power to operating switch or junction.	Check above. Tighten all loose wire connections. Correct any improper connections. Down Position Check for power across black and white leads. Up Position Check for power across red and white leads.
Screen will not operate and motor does not hum. Power at junction box.	Thermal overload tripped.	Let motor cool down for 15 minutes. Try again.
	Broken wire in the "down" or "up" position.	Check for continuity. Cut off old splice and reconnect.
	Defective motor, limit switch or capacitor.	Replace motor assembly. NOTE: Motor is a sealed assembly.
	Capacitor burned out.	Replace motor assembly.
Incorrect stopping position in downward direction.	Lost roller wrap.	See instructions below.
	"Down" limit switch out of adjustment.	See installation instructions.
Incorrect stopping position in upward direction.	Lost roller wrap.	See instructions below.
	"Up" limit switch out of adjustment.	Adjust "up" limit switch. Call for information.
Noise. NOTE: Screen will operate with a low pitched hum.	Squeaking, rubber end plug rubbing on motor.	Center roller in case.
	Grinding. Foreign object in screen rubbing on roller or fabric.	Remove.
	Gear noise.	Replace motor assembly.
Coasting.	Defective brake.	Replace motor assembly.

## Restoring Lost Roller Wrap

1. Tape a strap to the bottom of the screen surface.
2. Push strap over back of roller.
3. Feed fabric as you pull strap to draw fabric over top of roller.
4. Remove tape and strap.

## Conditions for Transportation and Storage

---

- Temperature: Between 40 - 100°F (5 - 40°C)
- Relative Humidity: 30% to 70%, non-condensing
- Always keep the projection screen horizontal during transport and storage
- Make sure the entire package is supported when stored
- Do not stack more than six projection screens on top of each other
- Make sure the heaviest package is placed at the bottom of the stack

**Screen surface should be allowed to air out once every two months, or otherwise used on a regular basis, if the temperature is above 72°F (22°C) and at least once every month if the temperature goes above 85°F (30°C).**

### **LIMITED FIVE YEAR WARRANTY ON DA-LITE PRESENTATION PRODUCTS**

Legrand AV Inc. warrants certain Da-Lite branded products to the original purchaser only, to be free from defects in materials and workmanship for a period of five (5) years from the date of purchase by the original purchaser; provided they are properly operated according to Da-Lite's instructions and are not damaged due to improper handling or treatment after shipment from the factory.

This warranty does not apply to equipment showing evidence of misuse, abuse or accidental damage, or which has been tampered with or repaired by a person other than authorized Da-Lite personnel.

Da-Lite's sole obligation under this warranty shall be to repair or to replace (at Da-Lite's option) the defective part of the merchandise. Returns for service should be made to your Da-Lite dealer. If it is necessary for the dealer to return the screen or part to Da-Lite, transportation expenses to and from Da-Lite are payable by the purchaser and Da-Lite is not responsible for damage in shipment. To protect yourself against damage or loss in transit, insure the product and prepay all transportation expenses.

**TO THE MAXIMUM EXTENT PERMITTED BY APPLICABLE LAW, THIS WARRANTY IS IN LIEU OF ALL OTHER WARRANTIES, EXPRESS OR IMPLIED, INCLUDING WARRANTIES AS TO FITNESS FOR USE AND MERCHANTABILITY.** Any implied warranties of fitness for use, or merchantability, that may be mandated by statute or rule of law are limited to the five (5) year warranty period. This warranty gives you specific legal rights, and you may also have other rights, which vary from state-to-state. **TO THE MAXIMUM EXTENT PERMITTED BY APPLICABLE LAW, NO LIABILITY IS ASSUMED FOR EXPENSES OR DAMAGES RESULTING FROM INTERRUPTION IN OPERATION OF EQUIPMENT, OR FOR INCIDENTAL, DIRECT, OR CONSEQUENTIAL DAMAGES OF ANY NATURE.**

In the event that there is a defect in materials or workmanship of a Da-Lite product, you may contact our Customer Care Specialists at 3100 North Detroit Street, Warsaw, IN 46582, (574) 267-8101, (800) 622-3737.

**IMPORTANT: THIS WARRANTY SHALL NOT BE VALID AND DA-LITE BRANDED PRODUCTS SHALL NOT BE BOUND BY THIS WARRANTY IF THE PRODUCT IS NOT OPERATED IN ACCORDANCE WITH THE DA-LITE WRITTEN INSTRUCTIONS.**

Keep your sales receipt to prove the date of purchase and your original ownership.



FOR YOUR IMAGE | [legrandav.com](http://legrandav.com)

**USA** P 866.977.3901 E [av.da-lite.support@legrand.com](mailto:av.da-lite.support@legrand.com)  
**CANADA** P 877.345.4329 E [av.da-lite.support@legrand.com](mailto:av.da-lite.support@legrand.com)  
**EMEA** P +31 495 580 840 E [av.emea.sales@legrand.com](mailto:av.emea.sales@legrand.com)  
**APAC** P +852 2145 4099 E [av.asia.sales@legrand.com](mailto:av.asia.sales@legrand.com)

© 2023 Legrand AV Inc. DL-0114 (Rev.5) 12/23 Da-Lite is a registered trademark of Legrand AV Inc.  
All other brand names or marks are used for identification purposes and are trademarks of their respective owners. All patents are protected under existing designations. Other patents pending.



COMMERCIAL BRANDS

Chief | Da-Lite | Middle Atlantic | Projecta | Vaddio