

Floor Model C

Portable Spring Roller Type Screen



SPECIFICATION DATA

SUGGESTED SPECIFICATIONS: _____ projection screen(s), _____(H) x _____(W), wall or ceiling mounting type. To have black masking borders standard on flame retardant and mildew resistant fiberglass fabric, mounted on a ball bearing rigid steel spring roller. Fabric to be permanently attached to roller. To have powder coated white 21-gauge steel case with flat back design. To have heavy-duty end caps concealing roller

ends with steel inner plates to support roller and provide added case strength. End caps shall form sturdy brackets for wall or ceiling installations. Bottom of screen shall be formed into pocket holding tubular metal slat. A steel pull bail shall be attached to the slat. The ends of the slat shall be protected by heavy duty plastic caps. Bumper stops shall be built into case to prevent slat wedging inside case.

Video (NTSC 4:3) Format Dimensions

Viewing Area (H x W)		Nominal Diagonal		A - Overall Length of Case		Approx. Ship. Wt.	
In.	Cm	In.	Cm	In.	Cm	Lbs.	Kg
69" x 92"	175 x 234	120"	305	99 ⁵ / ₁₆ "	252	50	22.7
87" x 116"	221 x 295	150"	381	123 ³ / ₁₆ "	313	58	26.3
105" x 140"	267 x 356	180"	457	147 ¹ / ₁₆ "	374	69	31.3

Square Format Dimensions

Sizes (H x W)		A - Overall Length of Case		Approx. Ship. Wt.	
In.	Cm	In.	Cm	Lbs.	Kg
8' x 8'	244 x 244	99 ⁵ / ₁₆ "	252	50	22.7
9' x 9'	274 x 274	111 ¹ / ₁₆ "	283	58	26.3
10' x 10'	305 x 305	123 ³ / ₁₆ "	313	65	29.5
12' x 12'	366 x 366	147 ¹ / ₁₆ "	374	79	35.8

PRODUCT NOTES

- **Matte White:** Horizontal seam required when both dimensions exceed 10'.
- Overall case length dimensions +/- 1/4".
- Detail dimensional drawings and installation instructions available upon request.
- Specifications subject to change without notice.
- Custom formats and sizes available upon request.

WHEN ORDERING, MARK APPROPRIATE SELECTIONS:

1. Select size from charts on the other side.
2. Select viewing surface (All Da-Lite surfaces are GREENGUARD GOLD Certified.):
 - Matte White
3. Choose Case Style
 - Black (Standard)
 - Carpeted
 - Black
 - Grey
4. Optional accessories:
 - No borders (Black masking borders standard)
 - Floor Stand (required for operation)

PRODUCT VIEW

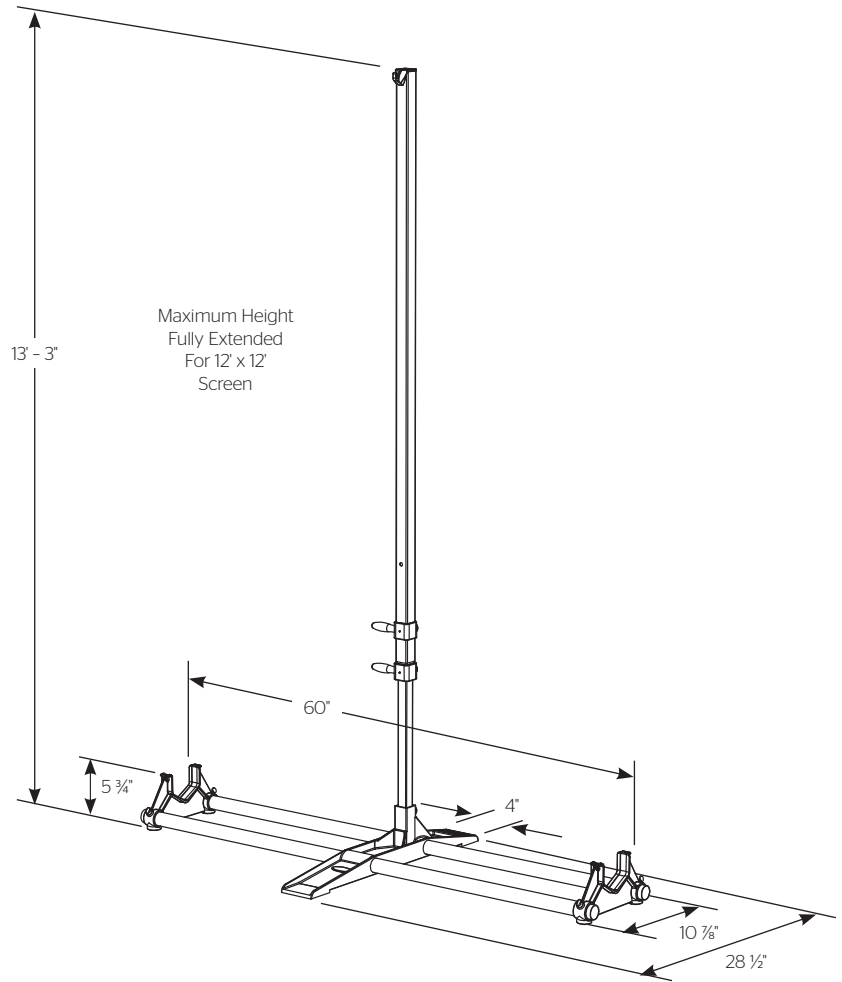
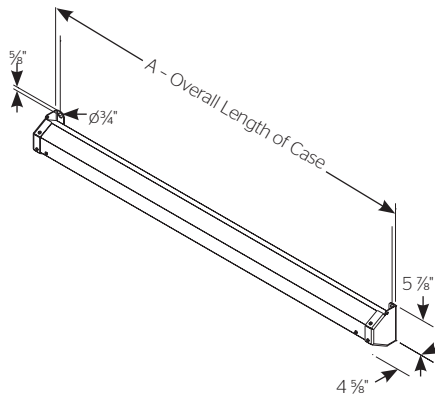
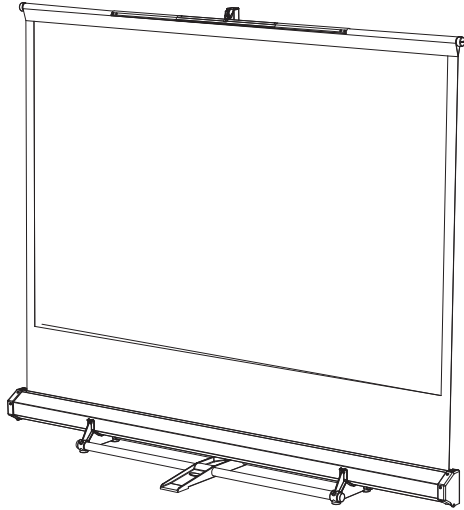

A BRAND OF MILESTONE AV TECHNOLOGIES

www.milestone.com

P 800.622.3737 / 574.267.8101

F 877.325.4832 / 574.267.7804

E info@da-lite.com

In British Columbia, Milestone AV Technologies ULC carries on business as MAVT Milestone AV Technologies ULC.

©2017 Milestone AV Technologies. DL-0323 (Rev. 2) 0717.
Da-Lite is a registered trademarks of Milestone AV Technologies. All other brand names or marks are used for identification purposes and are trademarks of their respective owners. All patents are protected under existing designations. Other patents pending.

Project Name:	_____
Architect:	_____
Contractor:	_____ Phone: _____
Reseller:	_____ Phone: _____