

# Tensioned Large Advantage® Deluxe Electrol®



Automatic Electric Projection Screen Model

SPECIFICATION DATA

**SUGGESTED SPECIFICATIONS:** \_\_\_\_\_ projection screen(s), \_\_\_\_\_(H) x \_\_\_\_\_(W). The Tensioned Advantage® Deluxe screen shall have two motors, one to operate door and one to operate screen. Door motor electrically operated 120 volt (60 Hz) not more than 1.2 amp. Shall have motor mounted inside the roller, to be three wire with ground, quick reversal type, oiled for life, with automatic thermal overload cutout, integral gears, capacitor and an electric brake to prevent coasting. To have pre-set but adjustable limit switches to automatically stop fabric door in the "down" position. The door will lift to the closed position where a micro switch shall cut off the electrical current to the door motor. The roller to be of 1.6" diameter aluminum. Screen motor is electrically operated 120 volt (60 Hz) not more than 2.4 amp. Shall have motor mounted inside the roller, to be three wire with ground quick reversal type, oiled for life, with automatic thermal overload cutout, integral gears, capacitor and an electric brake to prevent coasting. To have pre-set but adjustable limit switches to automatically stop picture surface in the "up" and "down" positions. The fabric roller to be of 4½" diameter (5¾" if 270" diagonal, 275" diagonal, or 298" diagonal) metal. Screen fabric to be seamless, flame retardant and mildew resistant vinyl, with black masking borders standard. Each side of the fabric to have tab guide cable system to maintain even lateral tension and hold surface flat. Custom slat bar with added

weight maintains vertical tension on the screen surface. The ends of the slat to be protected by heavy duty plastic caps enclosing a preset adjustable mechanism for screen tensioning. Case shall be a white powder coated extruded aluminum. Bottom of case to be self-trimming with a built-in flange around the bottom of the case. A section of the bottom of the case shall be a retractable aluminum door that opens and closes automatically with the lowering and raising of the picture surface. The balance of the bottom of the case shall be a second hinged aluminum door with manual opening to provide access. Hinges shall be mounted in a concealed way. Junction box shall be internally integrated into the housing making it possible to install the housing and wire to the building's electrical system during construction. The junction box shall contain a quick connect connector that is mounted in the housing for easy plug-in connection to the motorized fabric and roller assembly. The motorized fabric and roller assembly to be installed in the case at the factory or at a later time at the job site. To be complete with integrated low voltage control unit and three position control switch with cover plate. Suitable for use in environmental air space in accordance with section 300-22 (c) of the National Electric Code, and sections 2128, 12-010 (3) and 12-100 of the Canadian Electrical Code, part 1, CSA C22.1. Screen to be listed by Underwriters' Laboratories.



## HDTV (16:9) Format Dimensions

Viewing Area (H x W)		Nominal Diagonal		Overall Length of Case*		Approx. Ship. Wt.	
In.	Cm	In.	Cm	In.	Cm	Lbs.	Kg
108" x 192"	274 x 488	220"	559	221½"	562	688	312.1
121" x 216"	307 x 549	247"	627	247½"	628	764	346.5
135" x 240"	343 x 610	275"	699	273½"	694	841	381.5
146" x 260"	371 x 660	298"	757	294½"	748	870	394.6

## Wide (16:10) Format Dimensions

Viewing Area (H x W)		Nominal Diagonal		Overall Length of Case*		Approx. Ship. Wt.	
In.	Cm	In.	Cm	In.	Cm	Lbs.	Kg
110" x 176"	279 x 447	208"	528	205½"	523	691	313.4
120" x 192"	305 x 488	226"	574	222½"	565	729	330.7

## Video (NTSC 4:3) Format Dimensions

Viewing Area (H x W)		Nominal Diagonal		Overall Length of Case*		Approx. Ship. Wt.	
In.	Cm	In.	Cm	In.	Cm	Lbs.	Kg
126" x 168"	320 x 427	210"	533	199½"	507	628	284.9
132" x 176"	335 x 447	220"	559	208½"	530	655	297.1
144" x 192"	366 x 488	240"	610	226½"	574	708	321.1
162" x 216"	411 x 549	270"	686	251½"	639	781	354.3

\*Case length does not include flange

### PRODUCT NOTES

- All viewing surfaces will be seamless.
- All viewing surfaces are standard with black backing except Da-Tex® and Dual Vision.
- All screens standard with 12" black drop at the top, except 270" diagonal, which has 2".
- Extra drop may alter case dimensions. Contact Da-Lite for details.
- Overall case length dimensions +/- ¼" (6mm).
- Detail dimensional drawings, wiring diagrams and installation instructions available upon request.
- Specifications subject to change without notice.
- Custom formats and sizes available upon request.

### WHEN ORDERING, MARK APPROPRIATE SELECTIONS

- Select size from charts.
- Select viewing surface (All Da-Lite surfaces are GREENGUARD GOLD Certified.):
 

<input type="radio"/> HD Progressive 0.6	<input type="radio"/> Da-Mat®
<input type="radio"/> HD Progressive 0.9	<input type="radio"/> High Contrast Da-Mat®
<input type="radio"/> HD Progressive 1.1	<input type="radio"/> Da-Tex® (Rear)
<input type="radio"/> HD Progressive 1.1 Contrast	<input type="radio"/> Dual Vision
<input type="radio"/> HD Progressive 1.3	
- Options:
  - 220/240 Volt (50 Hz) Motor.
- Optional accessories:
 

<input type="checkbox"/> Wireless Remote Control for LVC.	<input type="checkbox"/> Key Locking Cover Plate for 120 V Switch or LVC.
<input type="checkbox"/> Radio Frequency Remote.	
<input type="checkbox"/> Radio Frequency Range Extender available.	
<input type="checkbox"/> Infrared Remote.	

**PRODUCT VIEWS**

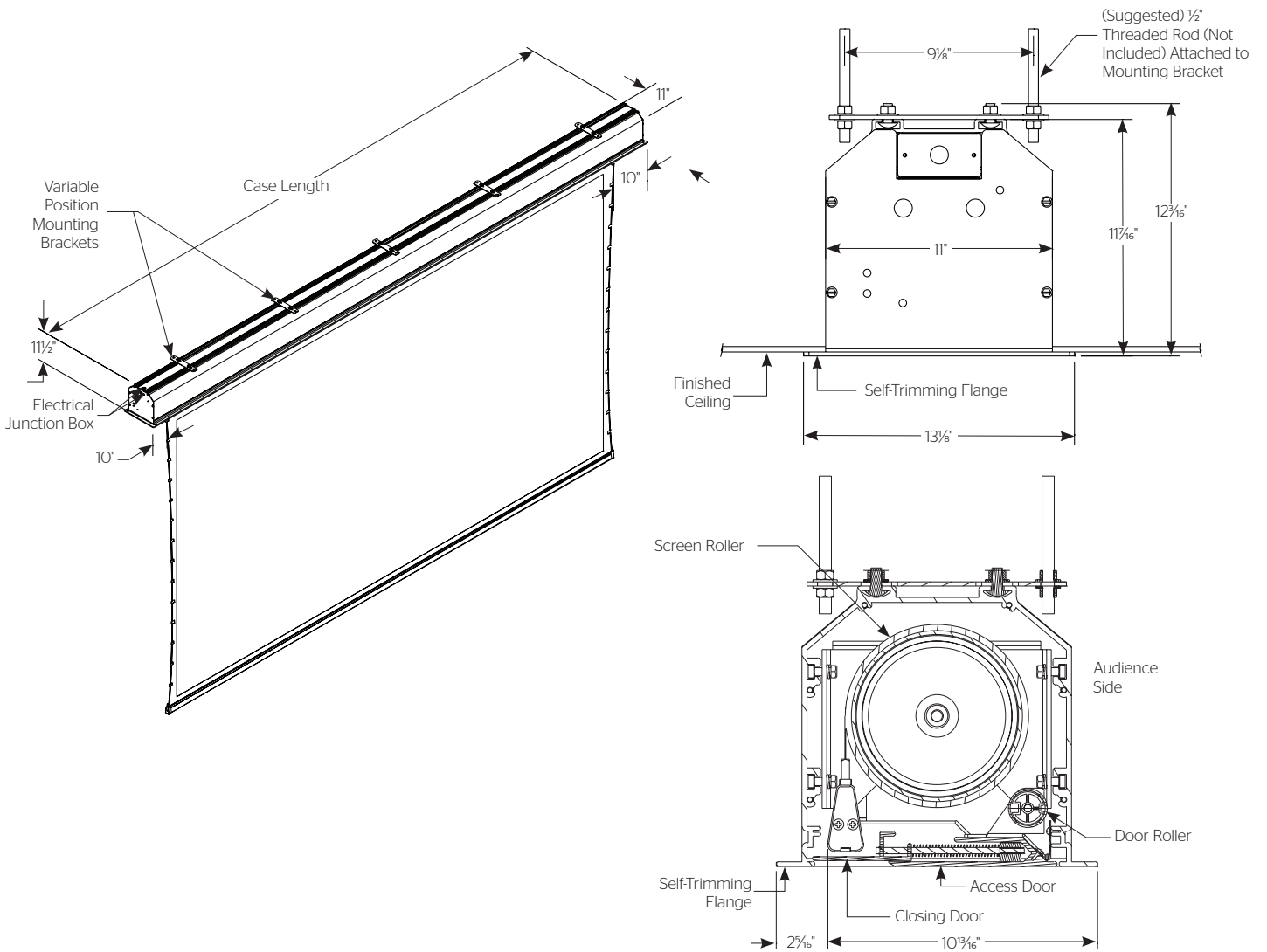

**A BRAND OF MILESTONE AV TECHNOLOGIES**

www.milestone.com

**P** 800.622.3737 / 574.267.8101

**F** 877.325.4832 / 574.267.7804

**E** info@da-lite.com

In British Columbia, Milestone AV Technologies ULC carries on business as MAVT Milestone AV Technologies ULC.

©2017 Milestone AV Technologies. DL-0196 (Rev. 4) 1217.  
 Da-Lite is a registered trademarks of Milestone AV Technologies. All other brand names or marks are used for identification purposes and are trademarks of their respective owners. All patents are protected under existing designations. Other patents pending.

Project Name: _____	
Architect: _____	Phone: _____
Contractor: _____	Phone: _____
Supervisor: _____	Phone: _____
Supplier: _____	Date: _____
Revised: _____	