



INSTRUCTION BOOK FOR
ViewShare Advantage Electrol



Original Instructions

Disclaimer

Milestone and its affiliated corporations and subsidiaries (collectively "Milestone"), intend to make this manual accurate and complete. However, Milestone makes no claim that the information contained herein covers all details, conditions or variations, nor does it provide for every possible contingency in connection with the installation or use of this subject to change without notice or obligation of any kind. Milestone makes no representation of warranty, expressed or implied, regarding the information contained herein. Milestone assumes no responsibility for accuracy, completeness or sufficiency of the information contained in this document.

Da-Lite® is a registered trademark of Milestone AV Technologies. All rights reserved.

Important Safety Instructions

When using your video equipment, basic safety precautions should always be followed, including the following:

1. Read and understand all instructions before using.
2. Position the cord so that it will not be tripped over, pulled, or contact hot surfaces.
3. If an extension cord is necessary, a cord with a current rating at least equal to that of the appliance should be used. Cords rated for less amperage than the appliance may overheat.
4. To reduce the risk of electric shock, do not disassemble this appliance. Contact an authorized service dealer when repair work is required. Incorrect reassembly can cause electric shock when the appliance is used subsequently.
5. The use of an accessory attachment not recommended by the manufacturer may cause a risk of fire, electric shock, or injury to persons.
6. Failure to provide adequate structural strength for this component can result in serious personal injury or damage to equipment! It is the installer's responsibility to make sure the structure to which this component is attached can support the weight of all equipment. Reinforce the structure as required before installing the component.
7. Use this projection screen only for its intended use as described in these instructions. Do not use attachments not recommended by the manufacturer.

Save These Instructions

Tools Required for Installation



1/2" Open Wrench
or Socket Driver

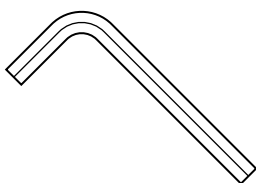

1/8" Hex Key
(included)

Pre-Installation

1. Carefully unpack case from shipping carton.
2. Set aside the Installation Kit. Items inside will be used during installation.
3. Make sure to recheck measurement of case for proper installation clearance.
4. Remove any protective foam covering the outside of the case.
5. For shipping purposes, foam is also inserted between the roller brackets and endcaps. Remove these foam blocks from the ends.
6. Remove the hanger brackets from the top of the case using a 1/2" wrench. Do not discard the hardware; it will be used during case installation to re-attach the hanger brackets for mounting.

Case Installation

1. Hang case and attach to support structure with bolts. See Suggested Methods of Installation.
2. Tighten bolts until trim flange is flush with ceiling.
NOTE: For proper operation, screen assembly must be level after installation.
3. Remove 2 screws to open junction box. Install electrical connections that apply to your unit. Make sure to review the wiring diagram for proper hook up. Replace junction box cover and secure with 2 screws.

NOTE: Must be installed in accordance with the requirements of the Local Building Codes, the Canadian Electrical Code (CEC), CAN/CSA C22.1 and the National Electric Code (NEC), NFPA 70.

If your case was ordered in advance of the screen and roller assembly, your installation is now complete. Continue to step 4 if your Advantage Electrol was ordered as a complete unit.

4. Use supplied 1/8" hex key to remove silver shipping brackets attached to slat and screen case.
5. Test installation by running screen up and down a few times. Be prepared to stop screen should any objects obstruct the movement of the screen. To prevent damage to the motor, the standard duty cycle is 1 minute on and 3 minutes off.

Suggested Methods of Installation

Method 1

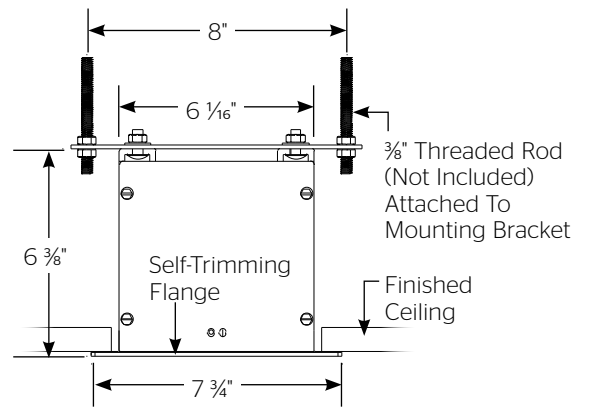
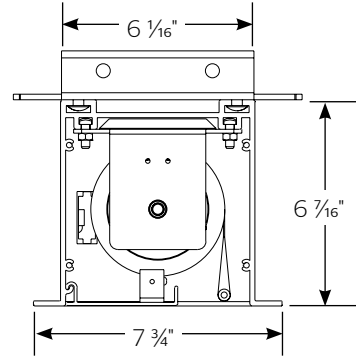
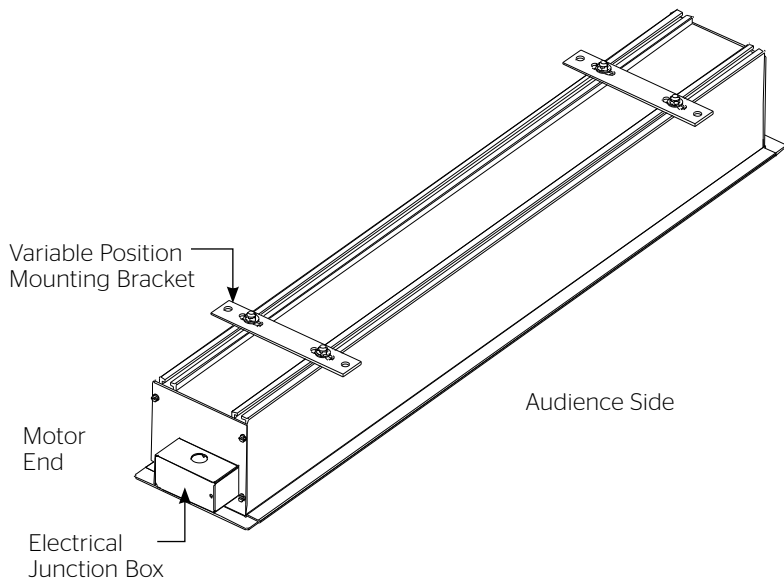

Method 2

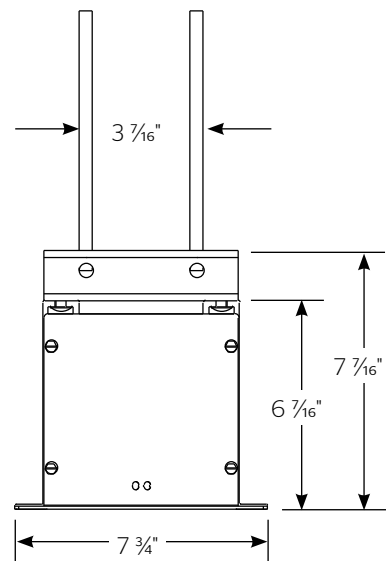
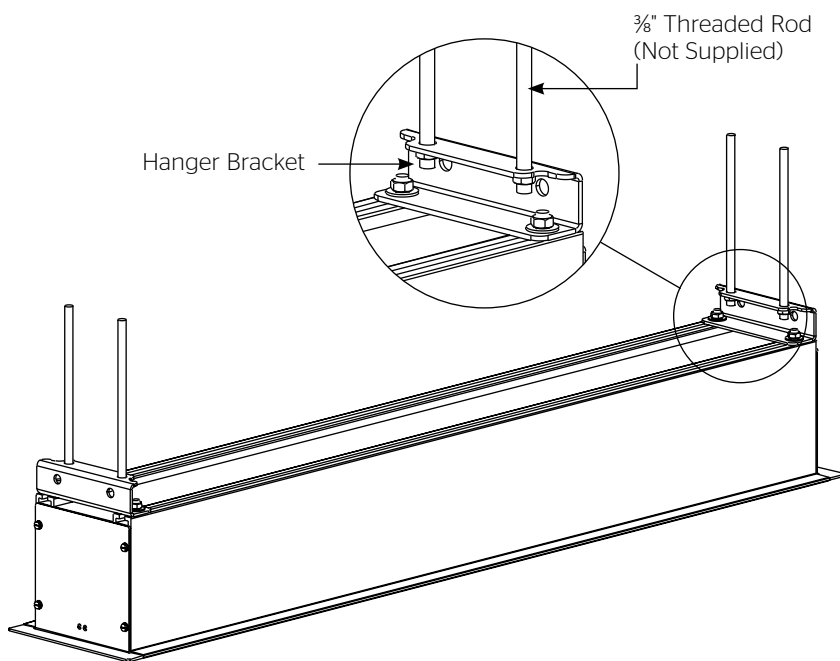

Wall Switch Installation for 120V Screens

120V Wiring Diagram

3-conductor 20-24 gauge wire can be used in place of the supplied RJ-14 cable to connect the wall switch. Connect the BUS terminals on the wall switch to the corresponding BUS terminals on the splitter board.

IMPORTANT NOTE: The wall switch is REQUIRED to make any limit switch adjustments, EVEN if a third party control system is used. Therefore, it is advised to wire the switch or provide a 3-conductor connection that is accessible.

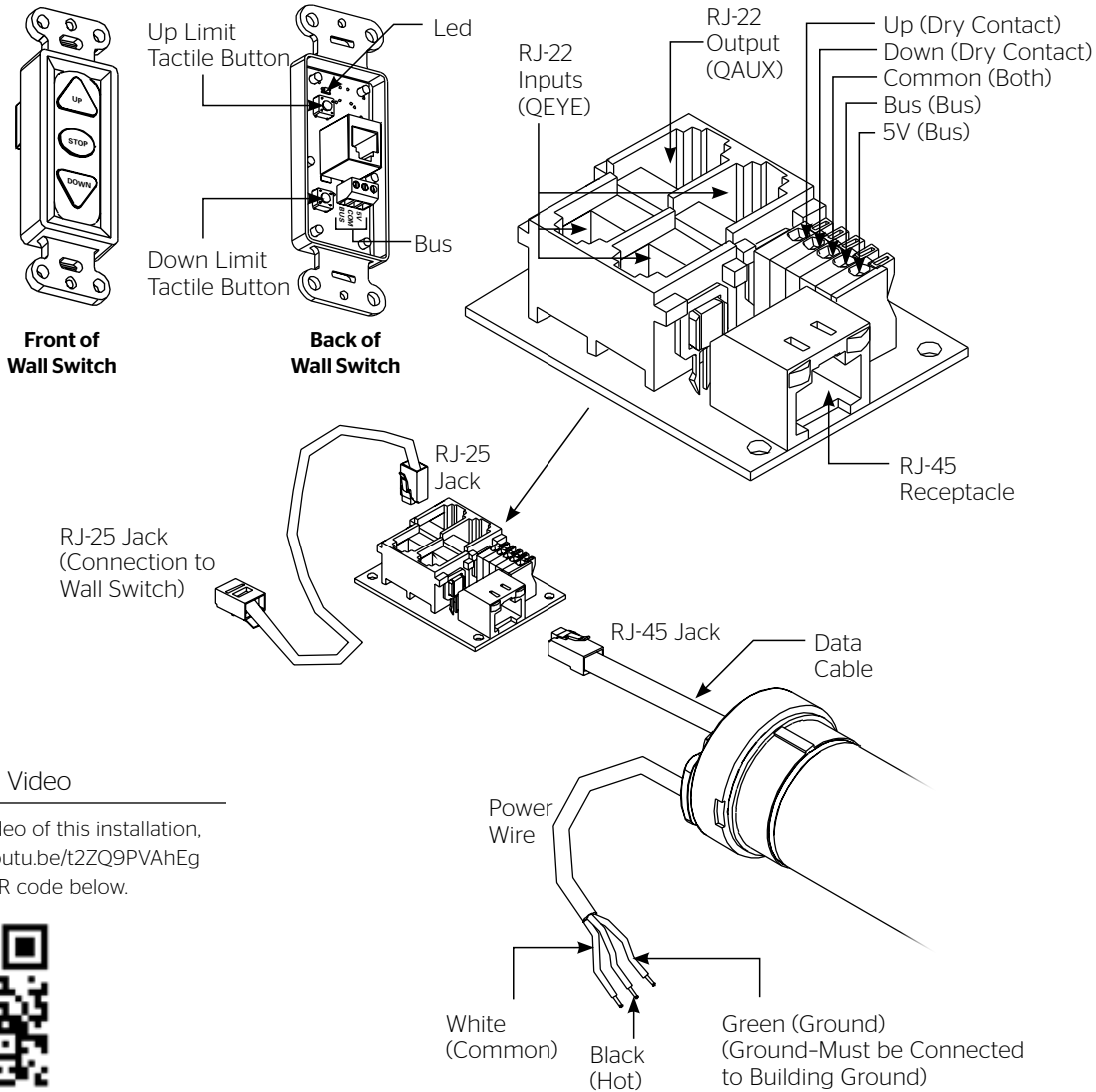

Installation Video

To view a video of this installation, visit <http://youtu.be/t2ZQ9PVAhEg> or use the QR code below.



Power Input 120VAC / 60Hz

RJ-14 Pin-Outs (Tab Is Facing Down)



Supplied RJ-14 cable

RJ-25 Pin-Outs (Tab Is Facing Down)

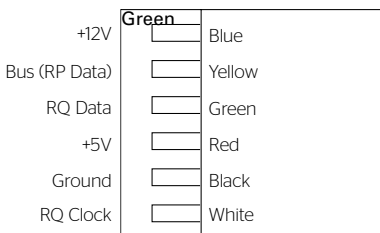

Standard RJ-25 can be used in place of RJ-14 cable

RJ-45 Pin-Outs (Tab Is Facing Down)

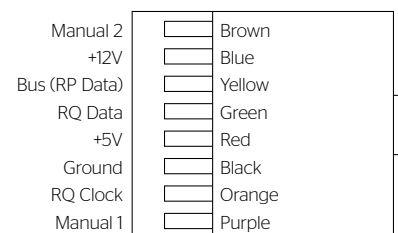

Video Projector Interface Installation for 120V Screens (Optional)

120V Wiring Diagram with Optional Built-In Video Projector Interface

⚠ CAUTION: The projector must be turned off before connecting the trigger wires to the projector. Failure to do so may damage the controller.

⚠ ATTENTION: Le projecteur doit être éteint avant de brancher les fils de déclenchement à celui-ci. Tout manquement à cette instruction pourrait endommager le contrôleur.

Use 2-conductor 20-24 gauge wire to extend the low voltage connection from the projector's 5 or 12-volt screen trigger output to the length required to reach the VPI. When extending the low voltage connection from the projector's screen trigger output polarity does not matter. The red and black wires from the VPI are interchangeable.

IMPORTANT NOTE: The wall switch is REQUIRED to make any limit switch adjustments, EVEN if a third party control system is used. Therefore, it is advised to wire the switch or provide a 3-conductor connection that is accessible.

3-conductor 20-24 gauge wire can be used in place of the supplied RJ-14 cable to connect the wall switch. Connect the BUS terminals on the wall switch to the corresponding BUS terminals on the splitter board.

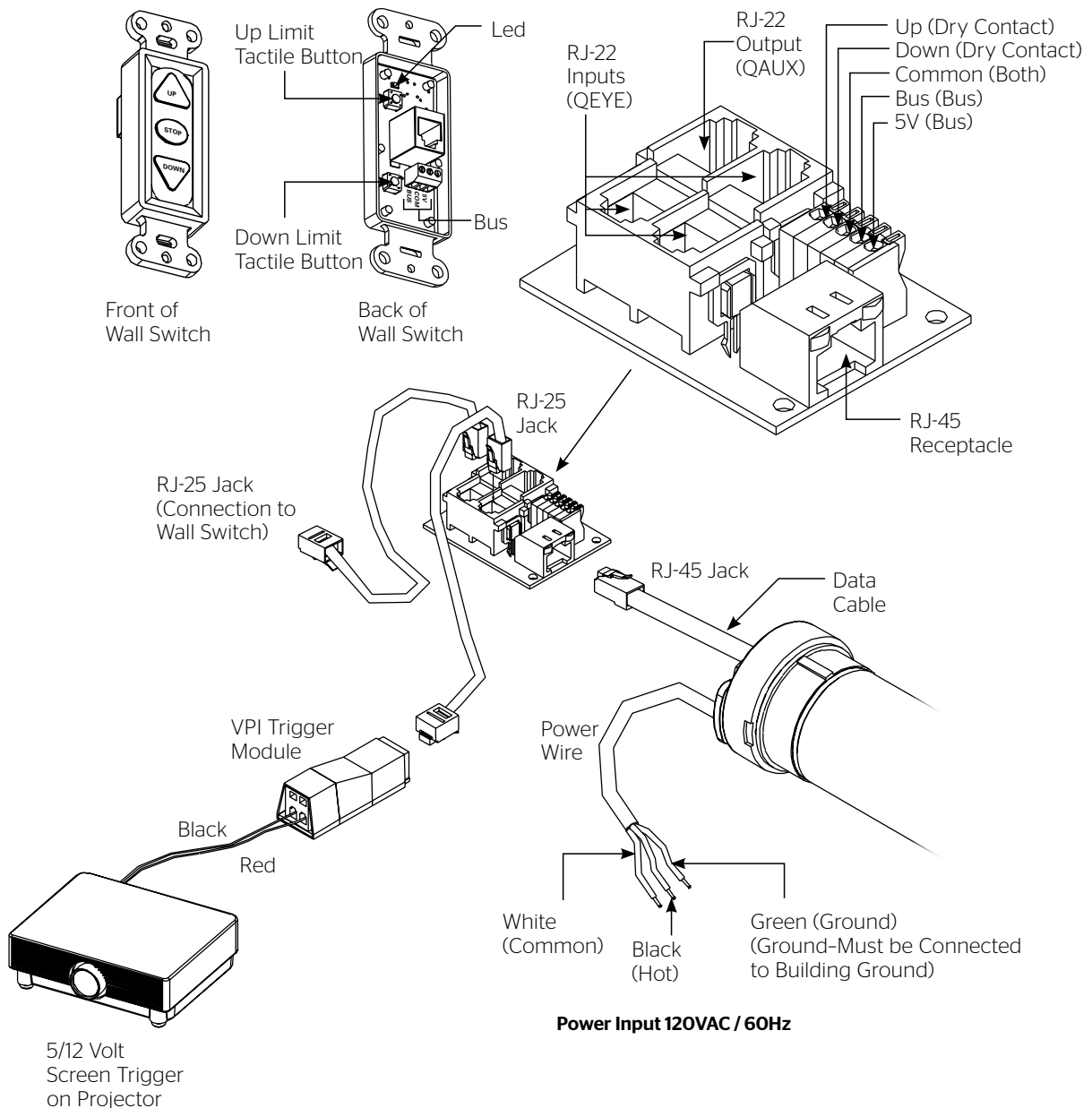

Low Voltage Connections for 120V Screens

Control Panel

A control panel may be connected to the splitter board by using the dry contact Up, Down and Common connections (see page 6). The control panel must provide a momentary, dry contact closure of at least 1/2 second.

1. Use 3-conductor 20-24 gauge wire to connect the control panel to the splitter board.
2. A momentary closure across the common and up wires will be an "up" command.
3. A momentary closure across the common and down wires will be a "down" command.
4. A momentary closure across the common, up and down wires will be a "stop" command.

Screen Adjustment for 120V Screens

If your Advantage Electrol was ordered as a complete unit, the up and down limits were pre-set by Da-Lite. If your screen and roller assembly was ordered separately from the case, or if general adjustment is needed, please follow the steps below and refer to the 120V Wiring Diagram

1. Locate the wall switch and remove the cover plate from the wall switch and remove the switch from the junction box.
2. Locate the two tactile buttons on the back of the switch. They are black round buttons on silver plates. See 120V Wiring Diagram.
3. To adjust the down limit switch, press and hold the down tactile button until the LED on the back of the switch turns solid red. This will put the motor in limit set mode. Turn the wall switch over and use the down button on the front of the switch. Press and hold the down button until the desired down position is reached. If you travel too far down, press the up button to move the screen upward. If you press and let go of either the up or down buttons, the motor will do a small jog in that direction for fine adjustment of the screen. Once the desired position is reached, turn the switch over; press and hold the down tactile button until the LED on back of switch blinks red twice. The down limit is now set.
NOTE: If the screen is in limit set mode and no buttons are pushed for 20 seconds, the LED on the back of the wall switch will turn off, the motor will return to run mode and no changes will be saved. If this occurs, return to step 3 for down limit adjustment or step 4 for up limit adjustment.
4. To adjust the up limit switch, press and hold the up tactile button until the LED on the back of the switch turns solid green. This will put the motor in limit set mode. Turn the wall switch over and use the up button on the front of the switch. Press and hold the

up button until the desired up position is reached. If you travel too far up, press the down button to move the screen downward. If you press and let go of either the up or down buttons, the motor will do a small jog in that direction for fine adjustment of the screen. Once the desired position is reached, turn the switch over; press and hold the up tactile button until the LED on back of switch blinks green twice. The up limit is now set.

5. To test the limit switch settings, press and release the up or down buttons on the switch to operate the screen.
6. Replace the switch and cover plate on the wall.

IMPORTANT NOTE: The wall switch is REQUIRED to make any limit switch adjustments, even if a third party control system is used. Therefore, it is advised to wire the switch or provide a 3-conductor connection that is accessible.

⚠ CAUTION: Do not adjust for more drop than what was ordered. At least 1-1/2 wraps of fabric must remain on the roller. This screen comes standard with 0" or 2" black at the top. See the specification data sheet for details.

⚠ ATTENTION! N'effectuez pas de réglage pour obtenir un déroulement supérieur à celui commandé. Au moins 1 à 1/2 tour de toile doit être maintenu sur le cylindre. Cet écran est doté de série d'une bande noire supérieure de 0 cm (0 po) ou 5 cm (2 po). Consultez la fiche technique pour plus de renseignements.

Wall Switch Installation for 220/240V Screens

240V Wiring Diagram

IMPORTANT NOTE: The wall switch is REQUIRED to make any limit switch adjustments, EVEN if a third party control system is used. Therefore, it is advised to wire the switch or provide a 4-conductor connection that is accessible.

ILT RJ-9 Pin-Outs (Tab Is Facing Down)

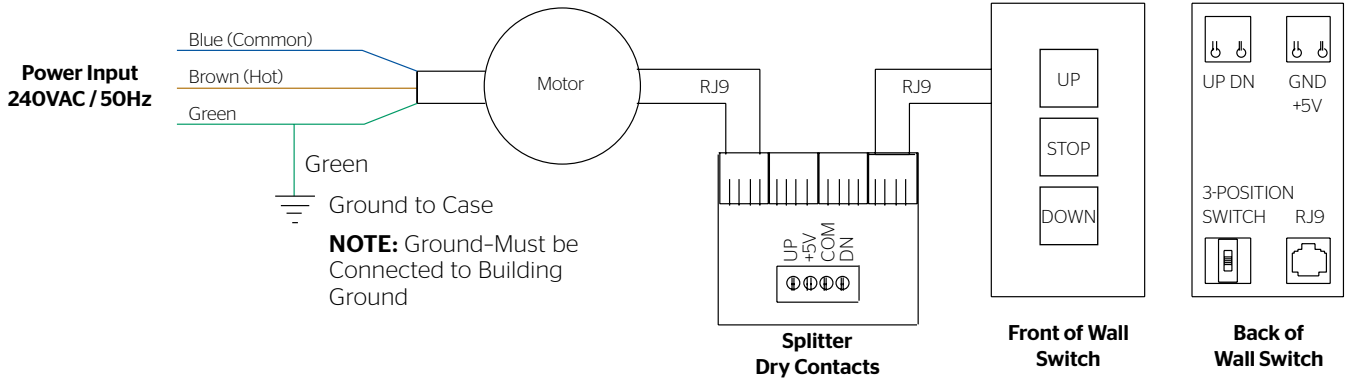

240V Wiring Diagram with Optional Built-in Video Projector Interface

CAUTION: The projector must be turned off before connecting the trigger wires to the projector. Failure to do so may damage the controller.

ATTENTION: Le projecteur doit être éteint avant de brancher les fils de déclenchement à celui-ci. Tout manquement à cette instruction pourrait endommager le contrôleur.

1. Use 2-conductor 20-24 gauge wire to extend the low voltage connection from the projector's 5 or 12-volt screen trigger output to the length required to reach the VPI. When extending the low voltage connection from the projector's screen trigger output, be

sure to maintain the proper polarity. The red wire from the VPI is the "signal" and the black wire from the VPI is the "ground".

2. Connect the wires from the VPI that are labeled "Low Voltage Connection" to the end of the extended screen trigger wires above.

IMPORTANT NOTE: The wall switch is REQUIRED to make any limit switch adjustments, EVEN if a third party control system is used. Therefore, it is advised to wire the switch or provide a 4-conductor connection that is accessible.

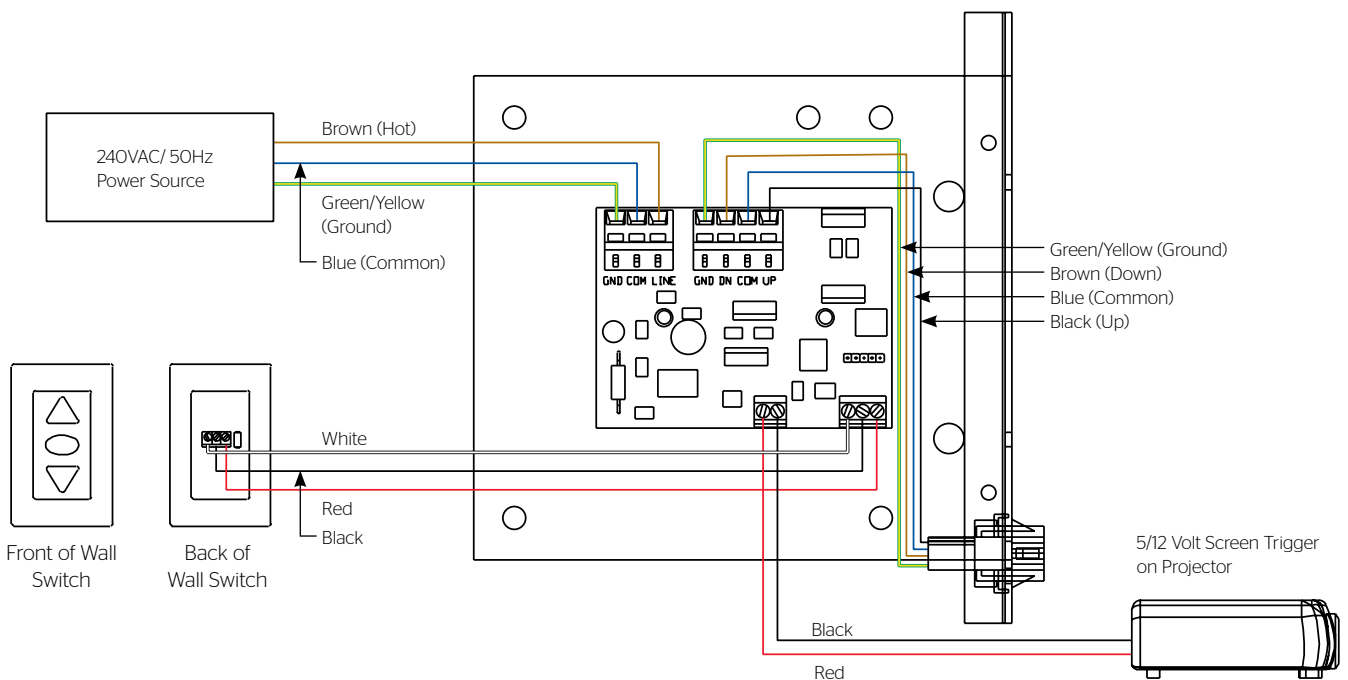

Low Voltage Connections for 220V/240V Screens

Control Panel

A control panel may be connected to the integrated LVC by using the wall switch wire lead. The control panel must provide a momentary, dry contact closure of at least 1/2 second.

1. Use 3-conductor 20-24 gauge wire to connect the control panel to the wall switch lead.
2. A momentary closure across the white and red wires will be an "up" command.
3. A momentary closure across the white and black wires will be a "down" command.
4. A momentary closure across the white, red and black wires will be a "stop" command.

Screen Adjustment for 220V/240V Screens

1. Remove the cover plate from the 3-button wall switch and remove the switch from the junction box.
2. Locate small 3-position switch on back of wall switch. See Figure 5 for 120V screens or Figure 8 for 220/240V screens.
3. To adjust the down limit switch, slide the 3-position switch to the down position. Press and hold the down button to run the screen down to the desired stop position. Release the button to stop the screen. **DO NOT PUSH THE STOP BUTTON.**
4. When the screen is in the desired down position, slide the 3-position switch to the off (center) position. The down limit switch is now set.
5. To adjust the up limit switch, slide the 3-position switch to the up position. Press and hold the up button to run the screen up to the desired stop position. Release the button to stop the screen. **DO NOT PUSH THE STOP BUTTON.**
6. When the screen is in the desired up position, slide the 3-position switch to the off (center) position. The up limit switch is now set.
7. To test limit switch setting, make sure the 3-position switch is in the off (center) position. Press and release the up or down button on the wall switch to operate the screen.

8. Replace switch and cover plate on the wall.

NOTE: If stop button is pressed, the wall switch will reverse direction. To correct this, press the stop button again. This will reset the switch. You will have to re-set both the up and the down limit settings.

IMPORTANT NOTE: The wall switch is REQUIRED to make any limit switch adjustments, EVEN if a third party control system is used. Therefore, it is advised to wire the switch or provide a 4-conductor connection that is accessible.

⚠ CAUTION: Do not adjust for more drop than what was ordered. At least 1-1/2 wraps of fabric must remain on the roller. This screen comes standard with 0" or 2" black at the top. See the specification data sheet for details.

⚠ ATTENTION! N'effectuez pas de réglage pour obtenir un déroulement supérieur à celui commandé. Au moins 1 à 1/2 tour de toile doit être maintenu sur le cylindre. Cet écran est doté de série d'une bande noire supérieure de 0 cm (0 po) ou 5 cm (2 po). Consultez la fiche technique pour plus de renseignements.

Camera and Speakerphone Installation

The following components are necessary for camera and speakerphone installation.

Included:

- Local CAT5 to USB Extender with Power Supply
- 6' USB Cable
- USB Speakerphone
- Powered USB Hub

You also will need enough CAT5 or CAT5e network cable to run from the ViewShare Advantage to the Local CAT5 to USB Extender. THE CAT5 CABLE IS NOT PROVIDED. The length of the CAT5 cable cannot exceed 200 feet.

For computer system requirements, specifications and troubleshooting, see the separate camera instruction located in the Installation Kit and the Speakerphone instruction located inside the Speakerphone box. Additionally, links to online assistance for each device are located in the Troubleshooting section of this instruction book.

Connections (see wiring diagram below)

1. Plug your CAT5 cable into connection port located on the left end of the ViewShare Advantage (Figure 1).
2. Connect your CAT5 cable to the Local CAT5 to USB Extender, which should be located near your computer. Connect the Local CAT5 to USB Extender power supply at this time.

NOTE: The CAT5 cable should only be connected between the ViewShare Advantage and the Local CAT5 to USB Extender. Do not connect to a server or network.

3. Lower the ViewShare Advantage screen and note the camera location in the center of the slat bar (Figure 2).
4. Use the 6' USB Cable to connect the Local CAT5 to USB Extender to the USB Hub.
5. Connect the Speakerphone to the Powered USB Hub.
6. Connect the USB Hub to your computer. Connect the USB Hub power supply at this time.

NOTE: The computer may recognize the USB Hub as a new component but It does not require any additional drivers. The USB Hub does not need to be used if your computer has two open USB ports.

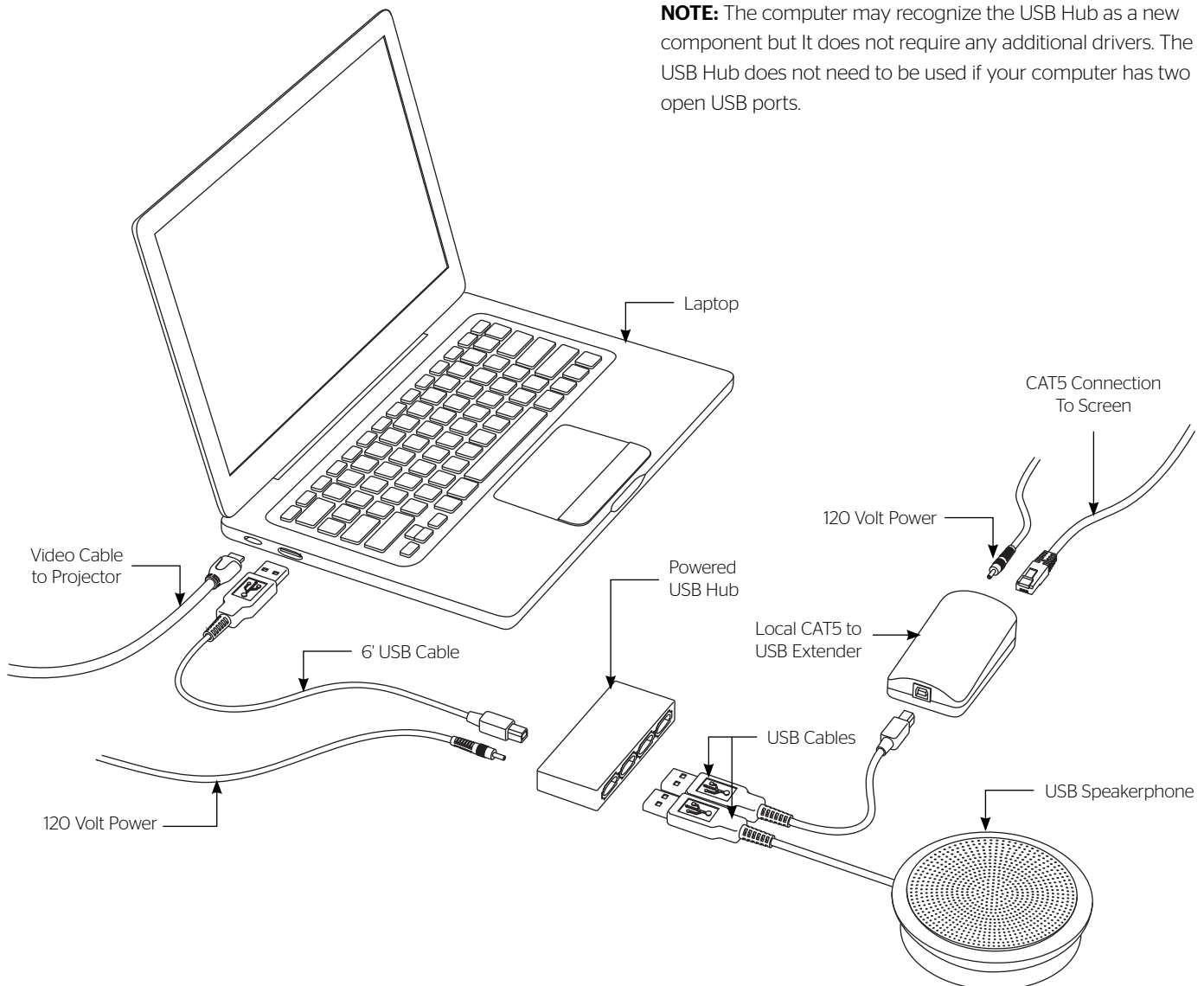

Camera and Speakerphone Setup

You are now ready to run the initial camera setup. The computer will recognize the camera as a new component and load the appropriate drivers. This can take up to several minutes and you may need to follow on-screen instructions. If the computer is using Windows 7 or later version, the computer will automatically detect the camera, choose the proper drivers, and install the drivers without your input. Once the green LED on the Local CAT5 to USB Extender is illuminated and the drivers are installed, you are ready to use the camera.

If the LED does not turn green after install, your computer may need to be restarted before the camera can be used. This could be a result of the type of operating system and other hardware/software installed, and is not necessarily a faulty device.

1. Open Lync, Skype or other compatible video calling software.
2. Go to the options menu and select "C930e" under the video devices.

NOTE: The Da-Lite bowtie around the camera will glow when the camera is selected. If the window says "No camera detected", go back to the Connections section and check each step.

3. In your software's options menu, select "Speakerphone 410" under the audio devices.

Installation is now complete and you are now ready to use your compatible video calling software.

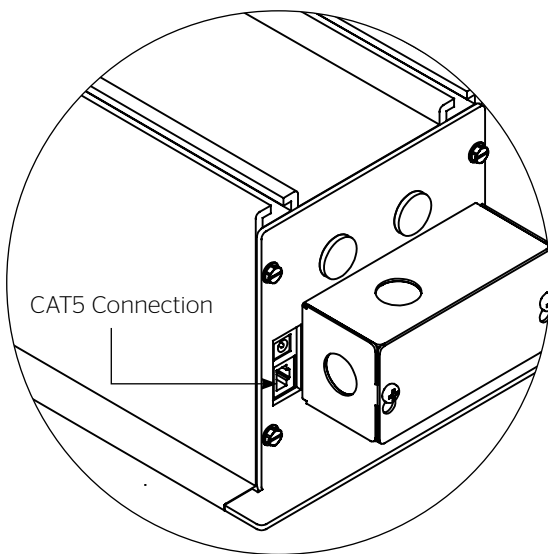

Figure 1

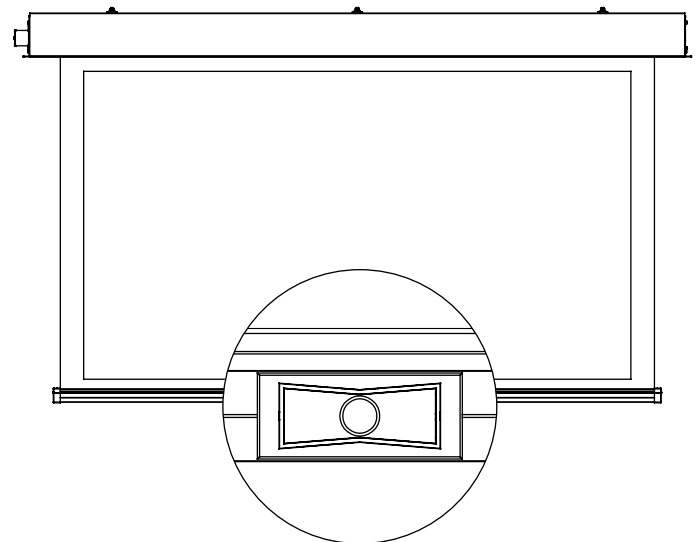

Figure 2

Troubleshooting

Symptom	Cause	Solution
Screen will not operate and motor does not hum.	Incorrect line voltage.	Verify 115-125V (or 220-240V). If insufficient voltage, rewire incoming electric line.
	Blown fuse.	Replace fuse.
	Tripped circuit breaker.	Reset circuit breaker.
	No power to operating switch or junction.	Check above. Tighten all loose wire connections. Correct any improper connections. Down Position Check for power across black and white leads. Up Position Check for power across red and white leads.
Screen will not operate and motor does not hum. Power at junction box.	Thermal overload tripped.	Let motor cool down for 15 minutes. Try again.
	Broken wire in the "down" or "up" position.	Check for continuity. Cut off old splice and reconnect.
	Defective motor, limit switch or capacitor.	Replace motor assembly. NOTE: Motor is a sealed assembly.
	Capacitor burned out.	Replace motor assembly.
Screen does not stop at correct position.	Limit switch out of adjustment.	See Screen Adjustment section.
Noise. NOTE: Screen will operate with a low pitched hum.	Squeaking, rubber end plug rubbing on motor.	Center roller in case.
	Grinding. Foreign object in screen rubbing on roller or fabric.	Remove.
	Gear noise.	Replace motor assembly.
Coasting.	Defective brake.	Replace motor assembly.
Fabric hangs crooked.	Screen not installed properly.	Check for level and plumb.
	Fabric has backed up inside case.	Adjust "down" limit switch slowly until roller is exposed and wrinkle comes out, then readjust for proper drop.
	Fabric is damaged.	Replace fabric.

Camera Support: <http://www.logitech.com/en-us/support/webcam-c930e-business?crd=405&osid=14&bit=64>

Speakerphone Support: http://www.jabra.com/support/Jabra-SPEAK-410-MS_7410-109

LIMITED WARRANTY - VIEWSHARE PRODUCTS

Milestone AV Technologies LLC warrants its Da-Lite branded ViewShare products to the original purchaser only, to be free from defects in materials and workmanship in accordance with the following warranty term:

A period of five (5) years for the Advantage screen and related components; and

A period of three (3) years for the ViewShare camera and related components.

The foregoing warranty will commence upon the date of purchase by the original purchaser and is expressly contingent upon the products being properly operated according to Da-Lite's instructions and not damaged due to improper handling or treatment after shipment from the factory.

This warranty does not apply to equipment showing evidence of misuse, abuse or accidental damage, or which has been tampered with or repaired by a person other than authorized Da-Lite personnel.

Da-Lite's sole obligation under this warranty shall be to repair or to replace (at Da-Lite's option) the defective part of the merchandise. Returns for service should be made to your Da-Lite dealer. If it is necessary for the dealer to return the screen or part to Da-Lite, transportation expenses to and from Da-Lite are payable by the purchaser and Da-Lite is not responsible for damage in shipment. To protect yourself against damage or loss in transit, insure the product and prepay all transportation expenses.

TO THE MAXIMUM EXTENT PERMITTED BY APPLICABLE LAW, THIS WARRANTY IS IN LIEU OF ALL OTHER WARRANTIES, EXPRESS OR IMPLIED, INCLUDING WARRANTIES AS TO FITNESS FOR USE AND MERCHANTABILITY. Any implied warranties of fitness for use, or merchantability, that may be mandated by statute or rule of law are limited to the above warranty period. This warranty gives you specific legal rights, and you may also have other rights, which vary from state-to-state. **TO THE MAXIMUM EXTENT PERMITTED BY APPLICABLE LAW, NO LIABILITY IS ASSUMED FOR EXPENSES OR DAMAGES RESULTING FROM INTERRUPTION IN OPERATION OF EQUIPMENT, OR FOR INCIDENTAL, DIRECT, OR CONSEQUENTIAL DAMAGES OF ANY NATURE.**

In the event that there is a defect in materials or workmanship of a Da-Lite product, you may contact our Customer Care Specialists at 3100 North Detroit Street, Warsaw, IN 46582, (574) 267-8101, (800) 622-3737.

IMPORTANT: THIS WARRANTY SHALL NOT BE VALID AND DA-LITE BRANDED PRODUCTS SHALL NOT BE BOUND BY THIS WARRANTY IF THE PRODUCT IS NOT OPERATED IN ACCORDANCE WITH THE DA-LITE WRITTEN INSTRUCTIONS.

Keep your sales receipt to prove the date of purchase and your original ownership.



A BRAND OF MILESTONE AV TECHNOLOGIES | www.milestone.com

P 800.622.3737 / 574.267.8101 **F** 877.325.4832 / 574.267.7804

E info@da-lite.com

In British Columbia, Milestone AV Technologies ULC carries on business as MAVT Milestone AV Technologies ULC.

©2016 Milestone AV Technologies. DL-0158 (Rev. 4) 1014.

Da-Lite is a registered trademark of Milestone AV Technologies. All other brand names or marks are used for identification purposes and are trademarks of their respective owners. All patents are protected under existing designations. Other patents pending.